

Data sheet

Pressure switch, Differential pressure switch RT



An RT pressure switch contains a pressure operated single-pole changeover contact, the position of which depends on the pressure in the inlet connection and the set scale value. The RT series includes pressure switches for general applications within industrial and marine refrigeration. The RT series also includes differential pressure switches, pressure switches for neutral zone regulation, and special pressure switches with gold-plated contact surfaces for PLC applications.

Features

- Versions with enclosure IP66
- Wide regulating range
- Wide range of units for industrial and marine applications
- Suitable for alternating and direct current (AC and DC)
- Interchangeable contact system
- Special versions for PLC applications
- Safety Integrity Level: SIL 2 according to IEC 61508

Approvals

RT 1	RT 1A	RT 1AL	RT 5A	RT 6W, RT 6B, RT 6S	RT 6AW, RT 6AB, RT 6AS	RT 30AW, RT 30AB, RT 30AS	RT 36B, RT 36S	RT 117	RT 117L	RT 200	RT 200L	RT 260A	RT 262A	
•				•		•		•		•				Germanischer Lloyd, GL
								•		•				Det Norske Veritas, DNV
								•		•				Bureau Veritas, BV
•	•							•		•		•	•	Registro Italiano Navale, RINA
•	•	•	•	•	•	•	•	•	•	•	•	•	•	Russian Maritime Register of Shipping, RMRS
•	•		•					•		•				Nippon Kaiji Kyokai, NKK
								•		•		•	•	Korean Register of Shipping, KRS
•	•	•	•	•	•	•	•	•	•	•	•	•	•	CE marked according to 60947-4, -5
				•	•	•	•							CE marked acc. to PED 97/23/EC category IV, safety equipment and EN 12263
•	•	•	•	•	•	•	•	•	•	•	•	•	•	China Compulsory Certificate, CCC

Technical data

Cable connection	2 × Pg 13.5 Cable diameter 6 – 14 mm
Enclosure	IP66 to EN 60529 / IEC 529, except for versions with ext. reset which are IP54
Ambient temperature	-50 – 70 °C for pressure control housing
Switches	See "Ordering, switches" (below)
Solid / stranded	0.2 – 2.5 mm ²
Flexible, without ferrules	0.2 – 2.5 mm ²
Flexible, with ferrules	0.2 – 1.5 mm ²
Tightening torque	max. 1.5 Nm
Rated impulse voltage	4 kV
Pollution degree	3
Short circuit protection, fuse	10 Amp
Insulation	400 V

Data sheet | Pressure switch, Differential pressure switch, type RT

Ordering

For R22, R134a, R404A, R407A, R407C, R407F, R422B, R422D

For complete list of approved refrigerants, visit www.products.danfoss.com and search for individual code numbers, where refrigerants are listed as part of technical data.

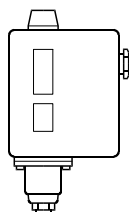

Pressure	Type	Regulation range [bar]	Differential Δp [bar]	Reset	Max. working pressure PS [bar]	Max. test pressure P _e [bar]	Code no.	
							Connection	
							¼ in flare	G 3/8 A ¹⁾
Low	RT 1	-0.8 – 5	0.5 – 1.6	Auto.	22	25	017-524566	–
		-0.8 – 5	0.5	Man. (Min.)	22	25	017-524666	–
	RT 200	0.2 – 6	0.25 – 1.2	Auto	22	25	–	017-523766
High	RT 117	10 – 30	1 – 4	Auto	42	47	–	017-529566

¹⁾ BSP ext. thread, ISO 228-1.

Safety – Pressure switches for

R22, R134a, R404A, R407A, R407C, R407F, R422B, R422D, R507A, R717^{*})

For complete list of approved refrigerants, visit www.products.danfoss.com and search for individual code numbers, where refrigerants are listed as part of technical data.

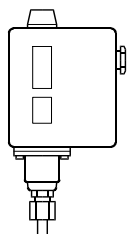

Pressure	Type	Regulation range [bar]	Differential Δp [bar]	Reset	Max. working pressure PS [bar]	Max. test pressure P _e [bar]	Code no.	
							Connection	
							Cutting ring ø6 mm	G 3/8 A ¹⁾ + weld nipple ø6.5/10 mm
Low	RT 1A	-0.8 – 5	0.5 – 1.6	Auto	22	25	017-501966	017-500166
		-0.8 – 5	0.5	Man. (Min.)	22	25	017-502766	017-500266
		-0.8 – 5	1.3 – 2.4	Auto	22	25	–	017-500766
High	RT 5A	4 – 17	1.2 – 4	Auto	22	25	017-505266	017-504666
		4 – 17	1.3	Man. (Max.)	22	25	017-506166	017-504766

¹⁾ BSP ext. thread, ISO 228-1.

^{*}) Only for RT 1A, RT 5A.

Safety pressure switches with EN 12263 approval and CE marked acc. PED (Pressure Equipment Directive)^{*})

R22, R134a, R404A, R407A, R407C, R407F, R422B, R422D, R507A, R717^{**)})

For complete list of approved refrigerants, visit www.products.danfoss.com and search for individual code numbers, where refrigerants are listed as part of technical data.

Pressure	Type	Regulation range [bar]	Differential (fixed) Δp [bar]	Reset [bar]	Max. working pressure PS [bar]	Max. test pressure P _e [bar]	Code no.			
							Connection			
							¼ in flare	Cutting ring ø6 mm	G 3/8 A ¹⁾ + weld nipple ø6.5/10 mm	G ½ A ¹⁾
High	RT 6W	5 – 25	3.0	Auto	34 ³⁾	38	017-503166	–	–	–
	RT 6B	10 – 28	1.0 ⁴⁾	Man. (Max.)	34 ³⁾	38	017-503466	–	–	–
	RT 6S	10 – 28	1.0 ⁴⁾	Man. (Max.)	34 ³⁾	38	017-507566	–	–	–
High	RT 30AW ²⁾	1 – 10	0.8	Auto	22	25	–	–	–	017-518766
	RT 30AB ²⁾	1 – 10	0.6 ⁴⁾	Man. (Max.)	22	25	–	–	–	017-518866
	RT 30AS ²⁾	1 – 10	0.4 ⁴⁾	Man. (Max.)	22	25	–	–	–	017-518966
High	RT 6AW	5 – 25	3.0	Auto	34 ³⁾	38	–	017-513166	017-503266	–
	RT 6AB	10 – 28	1.5 ⁴⁾	Man. (Max.)	34 ³⁾	38	–	017-513366	017-503566	–
	RT 6AS	10 – 28	1.5 ⁴⁾	Man. (Max.)	34 ³⁾	38	–	017-514666	017-507666	–

^{*}) Meets the requirements in VBG 20 on safety equipment and excess pressures.

W=Wächter (pressure control).

B= Begrenzer (pressure control with external reset).

S= Sicherheitsdruckbegrenzer (pressure control with internal reset).

A rupture in the bellows system of the unit will cause the compressor to stop.

^{**)} Only for RT 6AW, RT 6AB, RT 6AS, RT 30AW, RT 30AB, RT 30AS.

¹⁾BSP ext. thread, ISO 228-1.

²⁾Approved for PED also acc. to EN12953-9 and EN12922-11.

³⁾Max. working pressure acc. to PED is limited to 28 bar.

⁴⁾Max.

Data sheet | Pressure switch, Differential pressure switch, type RT
Ordering
(continued)

 Pressure switches with adjustable neutral zone for
 R22, R134a, R404A, R407A, R407C, R407F, R507A, R717 *)

 For complete list of approved refrigerants, visit www.products.danfoss.com and search for individual code numbers, where refrigerants are listed as part of technical data.

Pressure	Type	Regulation range [bar]	Differential Δp [bar]	Adjustable neutral zone NZ Δp [bar]	Max. working Pressure PS [bar]	Max. test pressure P_e [bar]	Code no.	
							Connection	
							Cutting ring $\varnothing 6$ mm	G 3/8 A ¹⁾ + weld nipple $\varnothing 6.5/10$ mm
Low	RT 1AL	-0.8 – 5	0.2	0.2 – 0.9	22	25	017L001666	017L003366
	RT 200L	0.2 – 6	0.25	0.25 – 0.7	22	25	–	017L003266 ²⁾
High	RT 5AL	4 – 17	0.35	0.35 – 1.4	22	25	017L001766 ²⁾	017L004066
	RT 117L	10 – 30	1.0	1 – 3.0	42	47	–	017L004266 ²⁾

¹⁾ BSP ext. thread, ISO 228-1.

²⁾ Without nipple.

^{*}) Only for RT 1AL, RT 5AL.

 Differential pressure switches for
 R22, R134a, R404A, R407A, R407C, R407F, R422B, R422D, R507A, R717

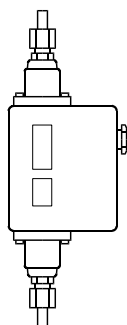
 For complete list of approved refrigerants, visit www.products.danfoss.com and search for individual code numbers, where refrigerants are listed as part of technical data.

Type	Regulation range [bar]	Differential Δp [bar]	Operating range for LP bellows [bar]	Max. working Pressure PS [bar]	Max. test pressure P_e [bar]	Code no.	
						Connection	
						Cutting ring $\varnothing 6$ mm	G 3/8 A ¹⁾ + weld nipple $\varnothing 6.5/10$ mm
RT 260A	0.5 – 4	0.3	-1 – 18	22	25	017D001466	017D002166
	0.5 – 4	0.3	-1 – 18	22	25	–	017D002266 ²⁾
	0.5 – 6	0.5	-1 – 36	42	47	017D001566	017D002366
	1.5 – 11	0.5	-1 – 31	42	47	017D001666	017D002466
RT 262A	0.1 – 1.5	0.1	-1 – 9	11	13	017D001366	017D002566
RT 265A ³⁾	1 – 6	0.5	-1 – 36	42	47	–	017D007266

¹⁾ BSP ext thread, ISO 228-1.

³⁾ Filter monitor: Alarm $\Delta p = 0.8$ bar, cut-out $\Delta p = 1$ bar (factory setting).

²⁾ Man. (Max.) reset.

 Differential pressure switches with adjustable neutral zone for
 R22, R134a, R404A, R407A, R407C, R407F, R422B, R422D, R507A, R717

 For complete list of approved refrigerants, visit www.products.danfoss.com and search for individual code numbers, where refrigerants are listed as part of technical data.

Type	Regulation range [bar]	Differential Δp [bar]	Adjustable neutral zone NZ [bar]	Operating range for LP bellows [bar]	Max. working pressure PS [bar]	Max. test pressure P_e [bar]	Code no.	
							Connection	
							G 3/8 A ¹⁾ + weld nipple $\varnothing 6.5/10$ mm	
RT 262 AL	0.1 – 1.5	0.1	0.1 – 0.33	-1 – 9	11	13	017D004366	

¹⁾ BSP ext thread, ISO 228-1.

Ordering
(continued)

 Switches ¹⁾

Contact system versions	Contact system	Description	Contact load	Code no.
With automatic reset	 SPDT	Single-pole changeover switch with terminal board proof against leakage current. Fitted in all standard versions of type RT. Snap action changeover contacts.	Alternating current ²⁾	017-403066
With manual (max.) reset	 SPDT	For manual reset of unit after contact changeover on rising pressure. For HP units prepared for reset facility.	Ohmic: AC 1 = 10 A, 400 V Inductive: AC 3 = 4 A, 400 V AC 15 = 3 A, 400 V Direct current DC 13 = 12 W, 220 V	017-404266
With manual (min.) reset	 SPDT	For manual reset of unit after contact changeover on falling pressure. For LP-units prepared for reset facility.	Direct current DC 13 = 12 W, 220 V	017-404166
With automatic reset, gold-plated	 SPDT	Single-pole changeover switch with gold plated (oxide-free) contact surfaces. Increases cut-in reliability on alarm and monitoring systems, etc. Snap action changeover contacts. Terminal board proof against leakage current.	Alternating current ²⁾ Ohmic: AC 1 = 10 A, 400 V Inductive: AC 3 = 2 A, 400 V AC 15 = 1 A, 400 V Direct current DC 13 = 12 W, 220 V	017-424066
Cuts in two circuits simultaneously	 SPST	Single-pole changeover switch that cuts in two circuits simultaneously on rising pressure. Snap action changeover contacts. Terminal board proof against leakage current.	Alternating current ²⁾ Ohmic: AC 1 = 10 A, 400 V Inductive: AC 3 = 3 A, 400 V AC 15 = 2 A, 400 V Direct current DC 13 = 12 W, 220 V ³⁾	017-403466
With non-snap action changeover contacts	 SPDT	Single-pole changeover switch with non-snap action changeover contacts.	Alternating or direct current 25 VA, 24 V	017-018166

¹⁾ RT pressure switches meet the conditions of EN 60947-2-9.

²⁾ Max. starting current (L.R.) = 7 × AC 3.

³⁾ If current is led through the contacts 2 and 4, i.e. terminals 2 and 4 connected but not terminal 1, the max. permissible load is increased by 90 W, 220V.

The switches are shown in the position they assume on falling pressure, i.e. after downward movement of the RT main spindle.

The setting pointer of the switch shows the scale value at which contact changeover occurs on falling pressure.

An exception is RT with switch code no. 017-404266 with Man. reset, where the setting pointer shows the scale value at which contact changeover occurs on rising pressure.

Special versions

RT can be supplied with special switches as follows.

When ordering, please state:

1. Type
2. Code no. of standard unit
3. Code no. of special switch

Design / Function

- 5. Setting knob
- 9. Regulation range scale
- 10. Loop terminal
- 11. Pg 13.5 screwed cable entry
- 12. Main spring
- 14. Terminals
- 15. Main spindle
- 16. Switch
- 17. Guide bush
- 18. Contact arm
- 19. Differential setting nut
- 23. Bellows element
- 25. Fixing hole
- 27. Connection
- 38. Earth terminal
- 39. Blow-out disc
- 44. Pressure setting spindle

Pressure switch, type RT

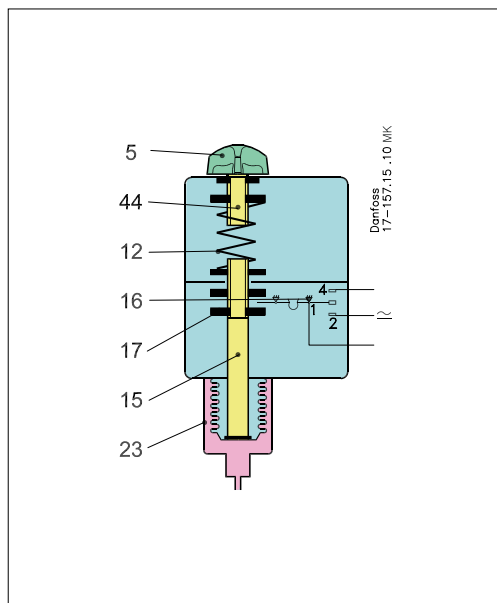

Pressure switch, type RT

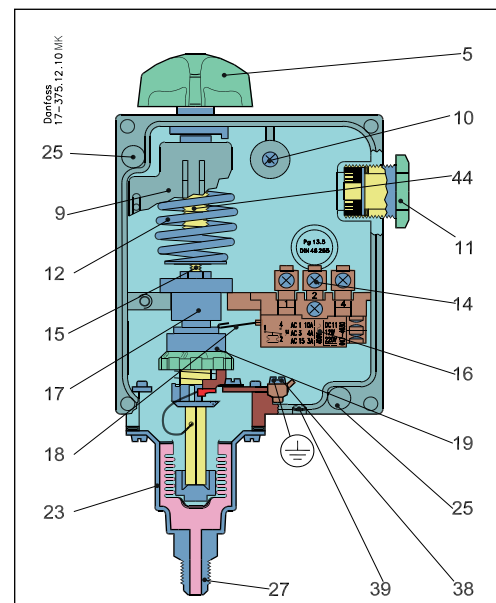

The bellows in the RT pressure switch is connected to the low or high pressure side of the controlled system via the connection.

By turning the setting knob (5) the main spring (12) can be set to balance the pressure in the bellows.

A rise in pressure compresses the bellows and moves the main spindle (15) upwards until spring and bellows pressure are in equilibrium. The main spindle (15) is fitted with a guide bush (17) and a differential pressure setting nut (19) that together transfer the main spindle movement to the switch (16).

The RT 6W, RT 6B, RT 6S, RT 6AW, RT 6AB, RT 6AS, RT 30AW, RT 30AB, RT 30AS, RT 36B, RT 36S are equipped with a double bellows (an outer bellows and a regulating bellows).

These units have been tested and approved by TÜV (Technischer Überwachungs Verein, Germany) according to EN 12263.

General for EN 12263 approved units.

1. The units are equipped with a double bellows system. When pressure in the plant exceeds the set value, the unit will automatically stop the plant. The double bellows system prevents loss of system charge in the event of bellows rupture.
2. Versions with designation W or AW cut again automatically when the pressure has fallen to the set value minus the differential.

3. Versions with designation B or AB are cut manually with the external reset button. This is possible when the pressure has fallen to the set value minus differential.

4. Versions with designation S or AS can be cut in manually with the internal reset arm when the pressure has fallen to the set value minus differential.

As laid down by EN 12263 requirements, if a rupture occurs in the regulating bellows of the unit, the refrigerating system compressor will be stopped and can only be restarted when the pressure control has been replaced.

A rupture in the outer bellows will cause the cut-out pressure of RT 36 to fall 2.5 bar, and the cut-out pressure of RT 6 and RT 30 to fall 4.5 bar under the set value. This means that the unit cuts out at normal condensing pressure and thus provides a fail-safe function.

All RT pressure switches, including those which are EN 12263 approved, operate independently of changes in the ambient temperature around the control housing. Therefore the set cut-out pressure and differential are held constant provided the permissible ambient temperatures are not exceeded.

Design / Function
(continued)

Pressure switch with adjustable neutral zone, type RT L

Pressure switch, type RT L

- 5. Setting knob
- 9. Regulation range scale
- 11. Pg 13.5 screwed cable entry
- 12. Main spring
- 15. Main spindle
- 16. Switch
- 17. Upper guide bush
- 18. 18a, 18b. Contact arm
- 20. Lower guide bush
- 23. Bellows element
- 25. Fixing hole
- 27. Connection
- 38. Earth terminal
- 39. Blow-out disc
- 40. Neutral zone setting nut
- 44. Pressure setting spindle

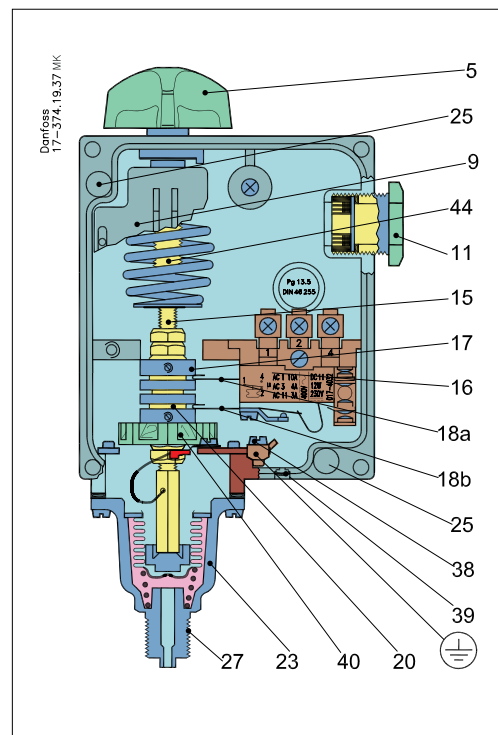
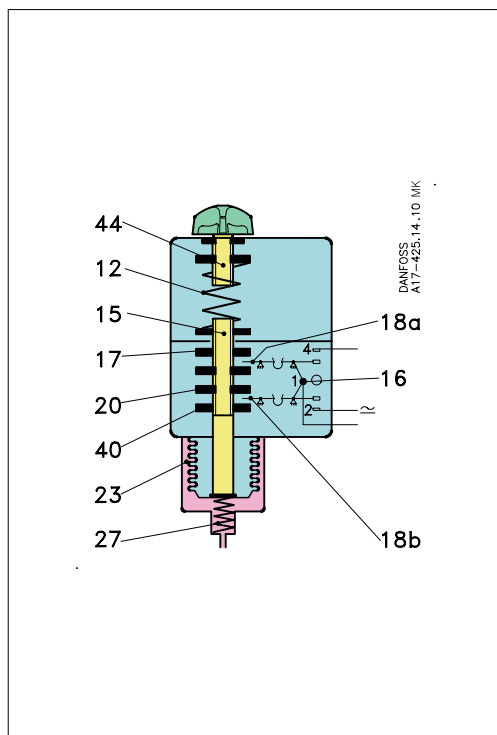

RT L pressure switches are fitted with a switch with an adjustable neutral zone. This enables the units to be used for floating control. The neutral zone switch contact arms (18a) and (18b) are operated by the spindle guide bushes (17) and (20).

The upper guide bush (17) is fixed while the lower guide bush (20) can be moved up or down by the setting nut (40). In this way the neutral zone can be varied between a minimum value (equal to the mechanical differential of the unit) and a maximum value (depending on the type of RT unit).

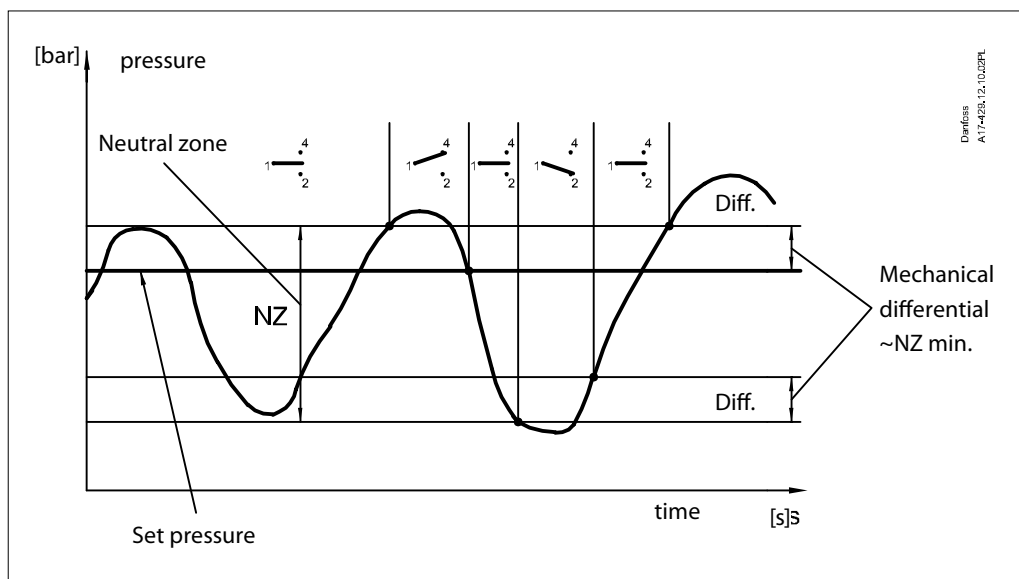

Design / Function
(continued)

Differential pressure switch, type RT

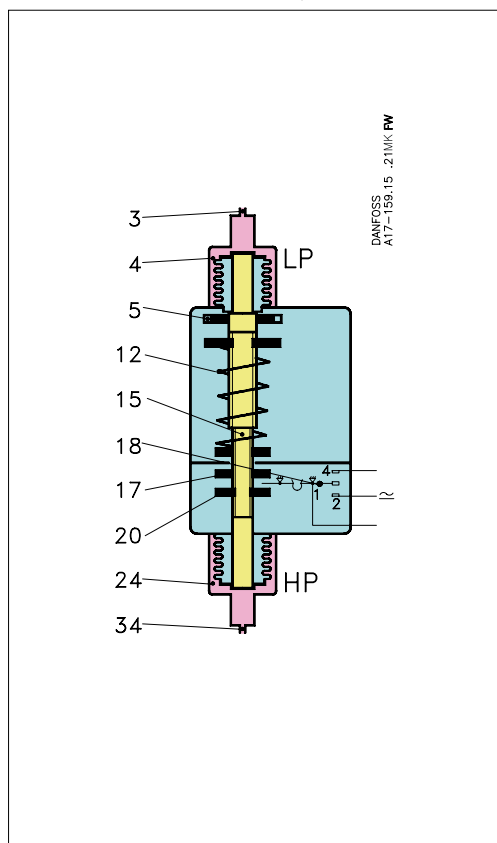

Differential pressure switch, type RT

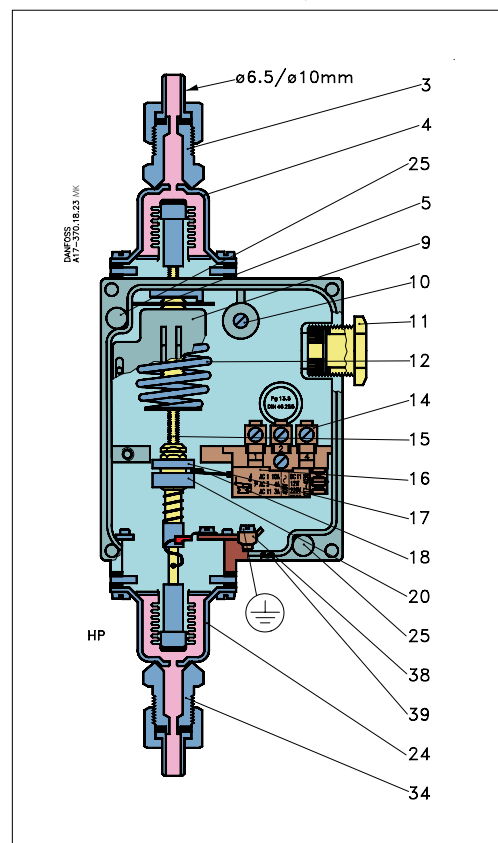

- 3. LP connection
- 4. LP bellows element
- 5. Setting disc
- 9. Regulation range scale
- 10. Coil clamp
- 11. Pg 13.5 screwed cable entry
- 12. Main spring
- 14. Terminals
- 15. Main spindle
- 16. Switch
- 17. Upper guide bush
- 18. Contact arm
- 20. Lower guide bush
- 24. HP bellows element
- 25. Fixing hole
- 34. HP connection
- 38. Earth terminal
- 39. Blow-out disc

An RT differential pressure switch contains a single-pole changeover switch that makes or breaks depending on the pressure differential between two counteracting bellows elements (LP and HP).

Differential pressure switches are used primarily as protection against too low a differential pressure across liquid circulation pumps. A secondary application is the safeguarding of lubricating oil pressure in refrigeration compressors.

The function of the pressure switch is conditional only on the differential pressure, i.e. the difference in pressure between the two counteracting bellows, whereas it is independent of the absolute pressure on both bellows.

The bellows (4) and (24) are respectively connected to the LP port (lowest pressure) and the HP port (highest pressure).

The main spring (12) can be set for different differential pressures by the setting disc (5). If the differential pressure between highest and lowest pressures falls, the spindle (15) moves downwards and via the upper guide bush (17), actuates the switch contact arm (18). The reverse function occurs if the differential pressure rises.

Terminology

Floating control

A form of delayed control where the correcting element (e.g. valve, damper, or similar) moves towards one extreme position at a rate independent of the magnitude of the error when the error exceeds a definite positive value, and towards the opposite extreme position when the error exceeds a definite negative value.

Hunting

Periodic variations of the controlled variable from the fixed reference.

Neutral zone

The interval between the make points of the two contacts.

“Snap function”

A certain contact force is maintained until the irrevocable “snap” is initiated. The time during which the contact force approaches zero is thus limited to a very few milliseconds. Therefore contact bounce cannot occur as a result of, for example, slight vibrations, before the cut-out point.

Contact systems with “Snap function” will change over even when micro-welds are created between the contacts during cut-in. A very high force is created during cut-out to separate the contacts. This force immediately shears off all the welds. Thus the cut-out point of the unit remains very accurate and completely independent of the magnitude of the current load.

Setting

RT with automatic reset – LP

The knob is used to set the lowest pressure at which the contact system must be activated (cut-out or cut-in).

This value can be read on the main scale of the unit.

The differential roller must be used to set the differential.

Highest activating pressure = lowest activating pressure + set differential.

RT with manual reset – LP

RT pressure switches RT 1 and RT 1A are obtainable in versions with min. reset. When the pressure falls to the setting value the pressure control cuts out.

Manual reset becomes possible when the pressure in the bellows system has risen to a value corresponding to the set value + the differential.

On falling pressure the follower activates the contact system arm and the contact changes over.

The scale is calibrated so that the scale value corresponds to contact changeover on falling pressure.

RT with automatic reset – HP

The knob can be used to set the lowest pressure at which the contact system must be activated (cut-out or cut-in).

This value can be read on the main scale of the unit.

The differential must be set with the differential roller. Highest activating pressure = lowest activating pressure + set differential.

RT with manual reset – HP

Pressure switch RT 5A is obtainable with max. reset. When the pressure has risen to the set value the pressure control cuts out.

Manual reset only becomes possible when the pressure has fallen to a value corresponding to the set pressure minus the differential.

The differential roller is then used as a follower. On rising pressure the differential roller activates the contact system arm and the contact changes over.

The scale is calibrated so that the scale values correspond to contact changeover on rising pressure, which is opposite to RT units with automatic reset.

**Dimensions [mm]
and weight [kg]**

RT pressure switch housing

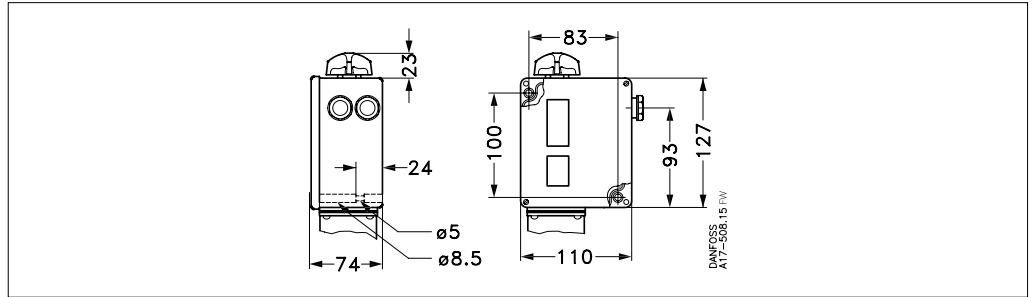

RT 1

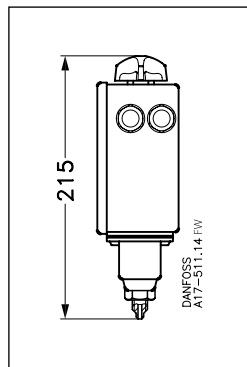

RT 1A, RT 1AL

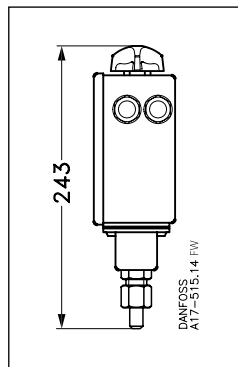

RT 1A, RT 1AL

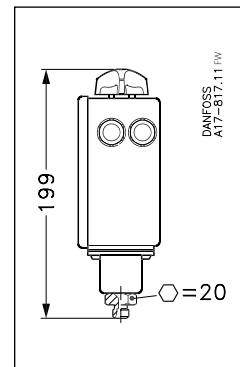

RT 6A

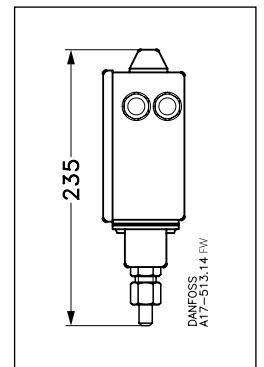

RT 6, RT 36

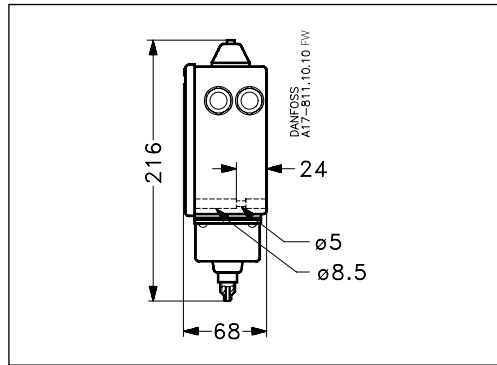

RT 30A

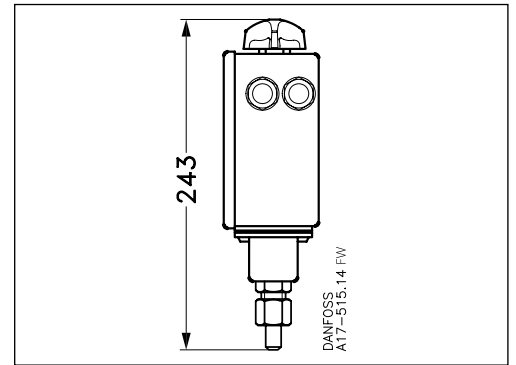

RT 117, RT 117L, RT 200, RT 200L

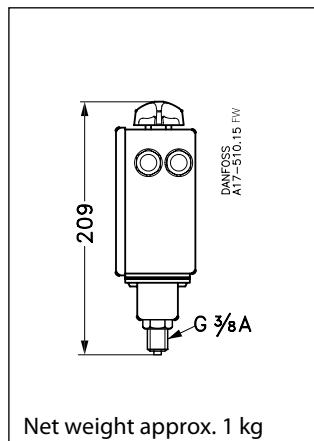

RT 260A

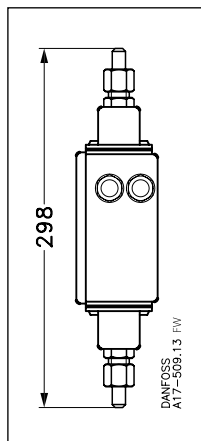

RT 262A

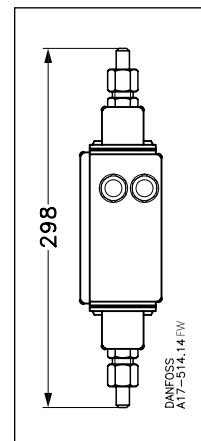

RT 260A, RT 262A

