

# EVD evolution

electronic expansion valve driver

# CAREL



**ENG** User manual

**LEGGI E CONSERVA  
QUESTE ISTRUZIONI**  
→ **READ AND SAVE  
THESE INSTRUCTIONS** ←



**READ CAREFULLY IN THE TEXT!**



WARNINGS



CAREL bases the development of its products on decades of experience in HVAC, on the continuous investments in technological innovations to products, procedures and strict quality processes with in-circuit and functional testing on 100% of its products, and on the most innovative production technology available on the market. CAREL and its subsidiaries nonetheless cannot guarantee that all the aspects of the product and the software included with the product respond to the requirements of the final application, despite the product being developed according to start-of-the-art techniques. The customer (manufacturer, developer or installer of the final equipment) accepts all liability and risk relating to the configuration of the product in order to reach the expected results in relation to the specific final installation and/or equipment. CAREL may, based on specific agreements, acts as a consultant for the positive commissioning of the final unit/application, however in no case does it accept liability for the correct operation of the final equipment/system.

The CAREL product is a state-of-the-art product, whose operation is specified in the technical documentation supplied with the product or can be downloaded, even prior to purchase, from the website [www.carel.com](http://www.carel.com). Each CAREL product, in relation to its advanced level of technology, requires setup/configuration/programming/commissioning to be able to operate in the best possible way for the specific application. The failure to complete such operations, which are required/indicated in the user manual, may cause the final product to malfunction; CAREL accepts no liability in such cases. Only qualified personnel may install or carry out technical service on the product. The customer must only use the product in the manner described in the documentation relating to the product.

In addition to observing any further warnings described in this manual, the following warnings must be heeded for all CAREL products:

- prevent the electronic circuits from getting wet. Rain, humidity and all types of liquids or condensate contain corrosive minerals that may damage the electronic circuits. In any case, the product should be used or stored in environments that comply with the temperature and humidity limits specified in the manual;
- do not install the device in particularly hot environments. Too high temperatures may reduce the life of electronic devices, damage them and deform or melt the plastic parts. In any case, the product should be used or stored in environments that comply with the temperature and humidity limits specified in the manual;
- do not attempt to open the device in any way other than described in the manual;
- do not drop, hit or shake the device, as the internal circuits and mechanisms may be irreparably damaged;
- do not use corrosive chemicals, solvents or aggressive detergents to clean the device;
- do not use the product for applications other than those specified in the technical manual.

All of the above suggestions likewise apply to the controllers, serial boards, programming keys or any other accessory in the CAREL product portfolio. CAREL adopts a policy of continual development. Consequently, CAREL reserves the right to make changes and improvements to any product described in this document without prior warning. The technical specifications shown in the manual may be changed without prior warning.

The liability of CAREL in relation to its products is specified in the CAREL general contract conditions, available on the website [www.carel.com](http://www.carel.com) and/or by specific agreements with customers; specifically, to the extent where allowed by applicable legislation, in no case will CAREL, its employees or subsidiaries be liable for any lost earnings or sales, losses of data and information, costs of replacement goods or services, damage to things or people, downtime or any direct, indirect, incidental, actual, punitive, exemplary, special or consequential damage of any kind whatsoever, whether contractual, extra-contractual or due to negligence, or any other liabilities deriving from the installation, use or impossibility to use the product, even if CAREL or its subsidiaries are warned of the possibility of such damage.

DISPOSAL

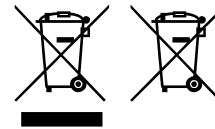

INFORMATION FOR USERS ON THE CORRECT HANDLING OF WASTE ELECTRICAL AND ELECTRONIC EQUIPMENT (WEEE)

In reference to European Union directive 2002/96/EC issued on 27 January 2003 and the related national legislation, please note that:

1. WEEE cannot be disposed of as municipal waste and such waste must be collected and disposed of separately;
2. the public or private waste collection systems defined by local legislation must be used. In addition, the equipment can be returned to the distributor at the end of its working life when buying new equipment;
3. the equipment may contain hazardous substances: the improper use or incorrect disposal of such may have negative effects on human health and on the environment;
4. the symbol (crossed-out wheeled bin) shown on the product or on the packaging and on the instruction sheet indicates that the equipment has been introduced onto the market after 13 August 2005 and that it must be disposed of separately;
5. in the event of illegal disposal of electrical and electronic waste, the penalties are specified by local waste disposal legislation.

**Warranty on the materials:** 2 years (from the date of production, excluding consumables).

**Approval:** the quality and safety of CAREL INDUSTRIES products are guaranteed by the ISO 9001 certified design and production system, as well as by the marks (\*).



READ CAREFULLY IN THE TEXT!

**CAUTION:** separate as much as possible the probe and digital input signal cables from the cables carrying inductive loads and power cables to avoid possible electromagnetic disturbance. Never run power cables (including the electrical panel wiring) and signal cables in the same conduits.



# Content

<b>1. INTRODUCTION</b>	<b>7</b>	<b>8. PARAMETERS TABLE</b>	<b>38</b>
1.1 Models .....	7	8.1 Unit of measure.....	42
1.2 Functions and main characteristics.....	7	8.2 Variables accessible via serial connection .....	42
<b>2. INSTALLATION</b>	<b>9</b>	8.3 Variables used based on the type of control.....	44
2.1 DIN rail assembly and dimensions .....	9	<b>9. ALARMS</b>	<b>45</b>
2.2 Description of the terminals.....	9	9.1 Alarms .....	45
2.3 Connection diagram - superheat control.....	9	9.2 Alarm relay configuration .....	46
2.4 Installation.....	10	9.3 Probe alarms.....	46
2.5 Valve operation in parallel and complementary mode.....	11	9.4 Control alarms.....	47
2.6 Shared pressure probe.....	11	9.5 EEV motor alarm.....	48
2.7 Connecting the module EVBAT00400.....	11	9.6 LAN error alarm .....	48
2.8 Connecting the USB-tLAN converter .....	11	<b>10.TROUBLESHOOTING</b>	<b>49</b>
2.9 Connecting the USB/RS485 converter.....	12	<b>11.TECHNICAL SPECIFICATIONS</b>	<b>51</b>
2.10 Upload, Download and Reset parameters (display).....	12	<b>12.APPENDIX: VPM (VISUAL PARAMETER MANAGER)</b>	<b>52</b>
2.11 Show electrical connections (display).....	12	12.1 Installation .....	52
2.12 General connection diagram.....	13	12.2 Programming (VPM).....	52
<b>3. USER INTERFACE</b>	<b>14</b>	12.3 Copying the setup .....	53
3.1 Assembling the display board (accessory).....	14	12.4 Setting the default parameters .....	53
3.2 Display and keypad.....	14	12.5 Updating the driver and display firmware.....	53
3.3 Display mode (display).....	15		
3.4 Programming mode (display) .....	15		
<b>4. COMMISSIONING</b>	<b>16</b>		
4.1 Commissioning .....	16		
4.2 Setting the pLAN network address.....	16		
4.3 Guided commissioning procedure (display).....	17		
4.4 Auxiliary refrigerant.....	19		
4.5 Checks after commissioning.....	19		
4.6 Other functions.....	19		
<b>5. CONTROL</b>	<b>20</b>		
5.1 Main and auxiliary control .....	20		
5.2 Superheat control.....	20		
5.3 Control with Emerson Climate Digital Scroll™ compressor .....	21		
5.4 BLDC Control with compressor.....	22		
5.5 Superheat regulation with 2 temperature probes.....	22		
5.6 Advanced regulation .....	23		
5.7 Programmable control.....	25		
5.8 Control with refrigerant level sensor.....	27		
5.9 Auxiliary control .....	27		
<b>6. FUNCTIONS</b>	<b>30</b>		
6.1 Power supply mode .....	30		
6.2 Battery charge delay .....	30		
6.3 Network connection.....	30		
6.4 Inputs and outputs .....	30		
6.5 Control status .....	32		
6.6 Advanced control status.....	34		
6.7 Quick probe alarm disabling.....	34		
<b>7. PROTECTORS</b>	<b>35</b>		
7.1 Protectors.....	35		



# 1. INTRODUCTION

EVD evolution is a driver for double pole stepper motors designed to control the electronic expansion valve in refrigerant circuits. It is designed for DIN rail assembly and is fitted with plug-in screw terminals. It controls refrigerant superheat and optimises the efficiency of the refrigerant circuit, guaranteeing maximum flexibility, being compatible with various types of refrigerants and valves, in applications with chillers, air-conditioners and refrigerators, the latter including subcritical and transcritical CO<sub>2</sub> systems. It features low superheat (LowSH), high evaporation pressure (MOP), low evaporation pressure (LOP) and high condensing temperature protection (HiTcond) (also for CO<sub>2</sub> cascade systems), and can manage, as an alternative to superheat control, special functions such as the hot gas bypass, the evaporator pressure control (EPR) and control of the valve downstream of the gas cooler in transcritical CO<sub>2</sub> circuits.

In the versions for CAREL valves, if integrated with a specific CAREL pCO controller via LAN, the driver can control one of the following:

- an electronic expansion valve in a refrigerant circuit with Emerson Climate Technologies Digital Scroll™ compressor;
- an electronic expansion valve in a refrigerant circuit with BLDC compressor. In this case the compressor must be controlled by the CAREL Power+ speed drive (with inverter), this in turn connected to the pCO controller.

The EVD evolution driver can control an electronic expansion valve in a refrigerant circuit with Digital Scroll compressor, if integrated with a specific CAREL controller via LAN. In addition, it features adaptive control that can evaluate the effectiveness of superheat control and if necessary activate one or more tuning procedures. Together with superheat control, it can manage an auxiliary control function selected between condensing temperature protection and “modulating thermostat”. As regards network connectivity, the driver can be connected to either of the following:

- a pCO programmable controller to manage the controller via pLAN, tLAN and RS485/Modbus®;
- a PlantVisorPRO supervisor via RS485/Modbus®. In this case, On/Off control is performed via digital input 1 or 2, if suitably configured. As well as control start/stop, digital inputs 1 and 2 can be configured for the following:
  - optimised valve control after defrost;
  - Valve forced open (100%);
  - control backup;
  - control safety.

The second digital input is available for optimised defrost management. Another possibility involves operation as a simple positioner with 4 to 20 mA or 0 to 10 Vdc analogue input signal. EVD evolution comes with a LED board to indicate the operating status, or a graphic display (accessory) that can be used to perform installation, following a guided commissioning procedure involving setting just 4 parameters: refrigerant, valve, pressure probe, type of main control (chiller, showcase, etc.). The procedure can also be used to check that the probe and valve motor wiring is correct. Once installation is complete, the display can be removed, as it is not necessary for the operation of the driver, or alternatively kept in place to display the significant system variables, any alarms and when necessary set the control parameters. The driver can also be setup using a computer via the service serial port. In this case, the VPM program (Visual Parameter Manager) needs to be installed, downloadable from <http://ksa.carel.com>, and the USB-tLAN converter EVDENV00E0 connected.

Only on RS485/ Modbus® models can the installation procedure be managed as described above by computer, using the serial port (see paragraph 2.8) in place of the service serial port. The “universal” models can drive all types of valves, while the CAREL models only drive CAREL valves.

## 1.1 Models

Code	Description
EVD0000E00	EVD evolution universal - tLAN
EVD0000E01	EVD evolution universal - tLAN, multiple pack of 10 pcs (*)
EVD0000E10	EVD evolution universal - pLAN
EVD0000E11	EVD evolution universal - pLAN, multiple pack of 10 pcs (*)
EVD0000E20	EVD evolution universal - RS485/Modbus®
EVD0000E21	EVD evolution universal - RS485/Modbus®, multiple pack of 10 pcs (*)
EVD0000E30	EVD evolution for CAREL valves - tLAN
EVD0000E31	EVD evolution for CAREL valves - tLAN, multiple pack 10 pcs (*)
EVD0000E40	EVD evolution for CAREL valves - pLAN
EVD0000E41	EVD evolution for CAREL valves - pLAN, multiple pack 10 pcs (*)
EVD0000E50	EVD evolution for CAREL valves - RS485/Modbus®
EVD0000E51	EVD evolution for CAREL valves - RS485/Modbus®, multiple pack 10 pcs
EVD0002E10	EVD evolution universal - pLAN opto-isolated
EVD0002E20	EVD evolution universal - RS485/Modbus® opto-isolated

Tab. 1.a

(\*)The codes with multiple packages are sold without connectors, available separately in code EVDCON0021.

## 1.2 Functions and main characteristics

In summary:

- electrical connections by plug-in screw terminals;
- serial card incorporated in the driver, based on the model (tLAN, pLAN, RS485/Modbus®);
- compatibility with various types of valves (“universal” models only) and refrigerants;
- activation/deactivation of control via digital input 1 or remote control via LAN, from pCO programmable controller;
- superheat control with protection functions for low superheat, MOP, LOP, high condensing temperature;
- adaptive superheat control;
- function to optimise superheat control for air-conditioning units fitted with Emerson Climate Digital Scroll™ compressor. In this case, EVD Evolution must be connected to a CAREL pCO series controller running an application program that can manage units with Digital Scroll compressors. This function is only available on the controllers for CAREL valves;
- configuration and programming by display (accessory), by computer using the VPM program or by PlantVisor/PlantVisorPro supervisor and pCO programmable controller;
- commissioning simplified by display with guided procedure for setting the parameters and checking the electrical connections;
- multi-language graphic display, with “help” function on various parameters;
- management of different units of measure (metric/imperial);
- parameters protected by password, accessible at a service (installer) and manufacturer level;
- copy the configuration parameters from one driver to another using the removable display;
- ratiometric or electronic 4 to 20 mA pressure transducer, the latter can be shared between up to 5 drivers, useful for multiplexed applications;
- possibility to use S3 and S4 as backup probes in the event of faults on the main probes S1 and S2;
- 4 to 20 mA or 0 to 10 Vdc input to use the driver as a positioner controlled by an external signal;
- management of power failures with valve closing (only for drivers with 24 Vac power supply and connected to the EVD0000UCO accessory);
- advanced alarm management.

Starting from software revision 4.0, new features hve been introduced:

- 24 Vac or 24 Vdc power supply, in the latter case without valve closing in the event of power failures;
- pre-position time settable by parameter;
- use of digital to start/stop control when there is no communication with the pCO programmable controller;
- possibility to control the electronic expansion valve in a refrigerant circuit with brushless DC motor (BLDC) compressor, controlled by CAREL Power+ speed drive (with inverter).

Starting from software revision 5.0, new features hve been introduced:

- management of new refrigerants;
- possibility to manage CO<sub>2</sub> cascade systems, setting the refrigerant on the primary circuit and on the secondary circuit;
- high condensing temperature protection (Reverse HiTcond) for CO<sub>2</sub> cascade systems;
- subcooling measurement;
- valve position in standby settable by parameter.

Starting from software revision 5.4, new features hve been introduced:

- programmable control, both superheat and special, and programmable positioner: these functions exploit CAREL's technology and know-how in terms of control logic;
- custom refrigerant selection;
- control with level sensor for flooded evaporator;
- control with level sensor for flooded condenser.

Starting from software revision 7.2-7.3, new features hve been introduced:

- battery charge delay;
- external signal 0 ... 5 V (for programmable positioner).

Starting from software revision 7.8/7.9, new features hve been introduced, including:

- probe alarm management;
- management of new valves.

Starting from software revision 9.0/9.1, new features hve been introduced, including:

- management of new refrigerants;
- quick probe alarm disabling.

**SERIES OF ACCESSORIES FOR EVD EVOLUTION**

**Display (code EVDIS00\*\*0)**

Easily applicable and removable at any time from the front panel of the driver, during normal operation displays all the significant system variables, the status of the relay output and recognises the activation of the protection functions and alarms. During commissioning, it guides the installer in setting the parameters required to start the installation and, once completed, can copy the parameters to other drivers. The models differ in the first settable language, the second language for all models is English. EVDIS00\*\*0 can be used to configure and monitor all the control parameters, accessible via password at a service (installer) and manufacturer level.



Fig. 1.a

**USB/tLAN converter (code EVDCNV00E0)**

The USB-tLAN converter is connected, once the LED board cover has been removed, to the service serial port underneath. Fitted with cables and connectors, it can connect EVD evolution directly to a computer, which, using the VPM program, can configure and program the driver. VPM can also be used to update the driver and display firmware.



Fig. 1.b



Fig. 1.c

**USB/RS485 converter (code CVSTDUMOR0)**

The converter is used to connect the configuration computer and the EVD evolution controllers, for RS485/Modbus® models only.



Fig. 1.d

**Ultracap module (P/N EVD0000UC0)**

The module, mounted on DIN rail, guarantees temporary power to the driver in the event of power failures, for enough time to immediately close the connected electronic valves (one or two). It avoids the need to install a solenoid valve. The module is made using Ultracap storage capacitors, which ensure reliability in terms of much longer component life than a module made with lead batteries. In just 4 minutes the module is ready to power two Carel valves again (or 5 minutes for pairs or other brand valves).



Fig. 1.e

**Valve cable E2VCABS\*00 (IP67)**

Shielded cable with built-in connector for connection to the valve motor. The connector code E2VCON0000 (IP65) can also be purchased on its own, to be wired.



Fig. 1.f

**Ferrite for electromagnetic disturbances**

In applications where electromagnetic disturbances may be present, it is possible to install ferrites to reduce any disturbances. The available ferrite is P/N: 0907858AXX Ferrite for valve cable.



Fig. 1.g

**Float level sensor (P/N LSR0013000)**

The level sensor measures the quantity of refrigerant in the heat exchanger. This is used when controlling the valve based on the liquid level in the flooded evaporator or condenser. Available with threaded or flanged connector.

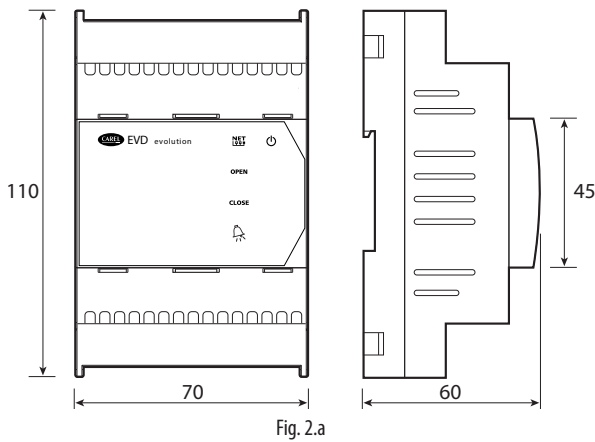

Fig. 1.h

## 2. INSTALLATION

### 2.1 DIN rail assembly and dimensions

EVD evolution is supplied with screen-printed connectors to simplify wiring.



### 2.2 Description of the terminals

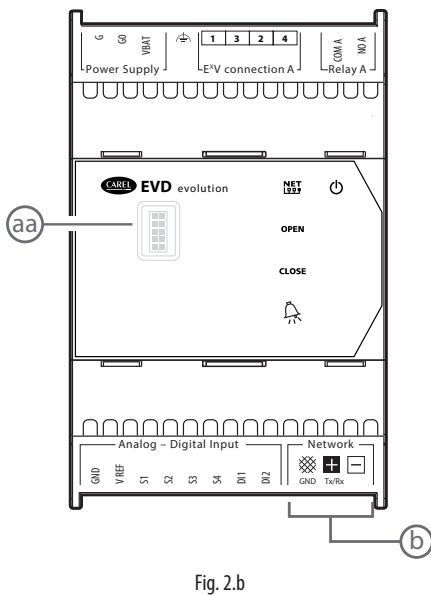

Terminal	Description
G, G0	Power supply
VBAT	Emergency power supply
	Functional earth
1,3,2,4	Stepper motor power supply
COM1, NO1	Alarm relay
GND	Earth for the signals
VREF	Power to active probes
S1	Probe 1 (pressure) or 4 to 20 mA external signal
S2	Probe 2 (temperature) or 0 to 10 V external signal
S3	Probe 3 (pressure)
S4	Probe 4 (temperature)
DI1	Digital input 1
DI2	Digital input 2
	Terminal for tLAN, pLAN, RS485, Modbus® connection
	Terminal for tLAN, pLAN, RS485, Modbus® connection
	Terminal for pLAN, RS485, Modbus® connection
aa	service serial port (remove the cover to access)
b	serial port

Tab. 2.a

### 2.3 Connection diagram - superheat control

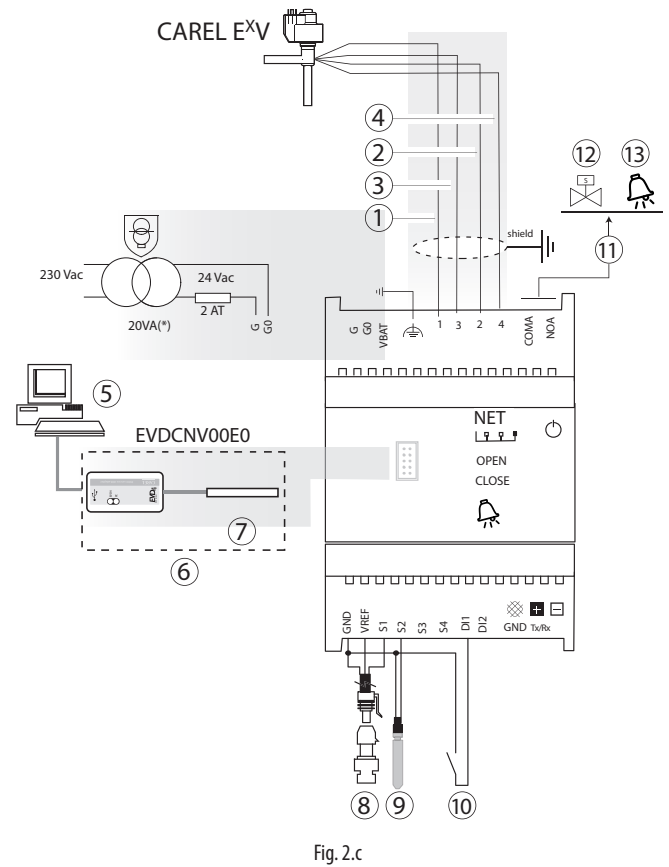

(\*) in combination with Alco EX7 or EX8 valves, use a 35 VA transformer (code TRADRFE240)

**Key:**

- 1 green
- 2 yellow
- 3 brown
- 4 white
- 5 personal computer for configuration
- 6 USB/tLAN converter
- 7 adapter
- 8 ratiometric pressure transducer - evaporation pressure
- 9 NTC suction temperature
- 10 digital input 1 configured to enable control
- 11 free contact (up to 230 Vac)
- 12 solenoid valve
- 13 alarm signal

**Note:**

- connect the valve cable shield to the electrical panel earth;
- the use of the driver for the superheat control requires the use of the evaporation pressure probe S1 and the suction temperature probe S2, which will be fitted after the evaporator, and digital input 1/2 to enable control. As an alternative to digital input 1/2, control can be enabled via remote signal (tLAN, pLAN, RS485/Modbus®). For the positioning of the probes relating to other applications, see the chapter on "Control";
- inputs S1, S2 are programmable and the connection to the terminals depends on the setting of the parameters. See the chapters on "Commissioning" and "Functions";
- pressure probe S1 in the diagram is ratiometric. See the general connection diagram for the other electronic probes, 4 to 20 mA or combined;
- four probes are needed for superheat control with BLDC compressors, two to measure the superheat and two to measure the discharge superheat and the discharge temperature. See chap. 5.

## 2.4 Installation

For installation proceed as follows, with reference to the wiring diagrams:

1. connect the probes: the probes can be installed a maximum distance of 10 metres away from the driver, or a maximum of 30 metres as long as shielded cables with a minimum cross-section of 1 mm<sup>2</sup> are used;
2. connect any digital inputs, maximum length 30 m;
3. connect the power cable to the valve motors: use 4-wire shielded cable AWG 22 L<sub>max</sub>=10 m or AWG 14 L<sub>max</sub>=50m; failure to connect the valve motors after connecting the driver will generate the "EEV motor error" alarm: see paragraph 9.5;
4. carefully evaluate the maximum capacity of the relay output specified in the chapter "Technical specifications";
5. if necessary use a class 2 safety transformer, suitably protected against short-circuits and voltage surges. For the power ratings see the general connection diagram and the technical specifications.
6. the minimum size of the connection cables must be 0.5 mm<sup>2</sup>
7. power up the driver in the event of 24 Vdc power supply the drive will close the valve.

**! Important:** in the event of 24 Vdc power supply set the "Power supply mode" parameter=1 to start control. See par. 6.1.

8. program the driver, if necessary: see the chapter "User interface";
9. connect the serial network, if featured: follow to the diagrams below for the earth connection.

### Drivers in a serial network

**Case 1:** multiple drivers connected in a network powered by the same transformer. Typical application for a series of drivers inside the same electrical panel.

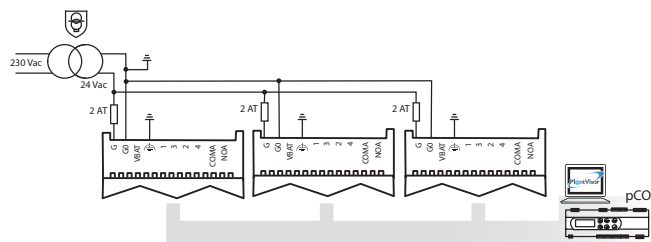

Fig. 2.d

**Case 2:** multiple drivers connected in a network powered by different transformers (G0 not connected to earth). Typical application for a series of drivers in different electrical panels.

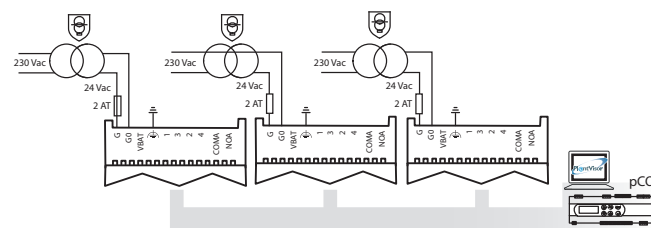

Fig. 2.e

**Case 3:** multiple drivers connected in a network powered by different transformers with just one earth point. Typical application for a series of drivers in different electrical panels.

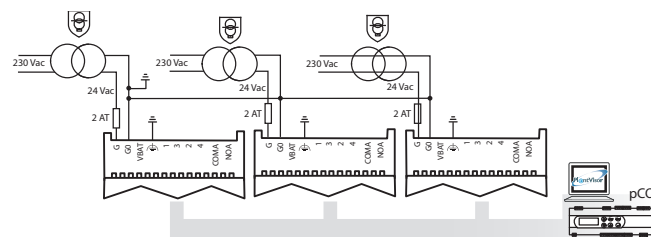

Fig. 2.f

**! Important:** earthing G0 and G on a driver connected to a serial network will cause permanent damage to the driver.

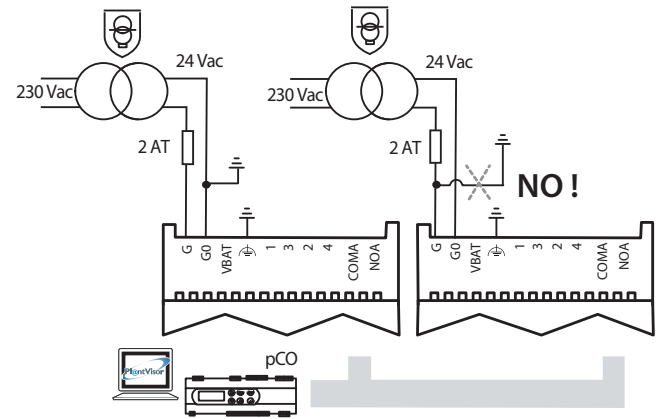

Fig. 2.g

### Installation environment

**! Important:** avoid installing the driver in environments with the following characteristics:

- relative humidity greater than the 90% or condensing;
- strong vibrations or knocks;
- exposure to continuous water sprays;
- exposure to aggressive and polluting atmospheres (e.g.: sulphur and ammonia fumes, saline mist, smoke) to avoid corrosion and/or oxidation;
- strong magnetic and/or radio frequency interference (avoid installing the appliances near transmitting antennae);
- exposure of the driver to direct sunlight and to the elements in general.

**! Important:** When connecting the driver, the following warnings must be observed:

- if the driver is used in a way not specified in this manual, the level of protection is not guaranteed.
- incorrect connection to the power supply may seriously damage the driver;
- use cable ends suitable for the corresponding terminals. Loosen each screw and insert the cable ends, then tighten the screws and lightly tug the cables to check correct tightness;
- separate as much as possible (at least 3 cm) the probe and digital input cables from the power cables to the loads so as to avoid possible electromagnetic disturbance. Never lay power cables and probe cables in the same conduits (including those in the electrical panels);
- install the shielded valve motor cables in the probe conduits: use shielded valve motor cables to avoid electromagnetic disturbance to the probe cables;
- avoid installing the probe cables in the immediate vicinity of power devices (contactors, circuit breakers, etc.). Reduce the path of the probe cables as much as possible and avoid enclosing power devices;
- avoid powering the driver directly from the main power supply in the panel if this supplies different devices, such as contactors, solenoid valves, etc., which will require a separate transformer;
- \* EVD EVO is a control to be incorporated in the end equipment, do not use for flush mount
- \* DIN VDE 0100: Protective separation between SELV circuit and other circuits must be guaranteed. The requirements according to DIN VDE 0100 must be fulfilled. To prevent infringement of the protective separation (between SELV circuit to other circuits) an additional fixing has to be provided near to the terminals. This additional fixing shall clamp the insulation and not the conductor".

## 2.5 Valve operation in parallel and complementary mode

EVD evolution can control two CAREL valves (same model) connected together, in parallel mode, with identical behaviour, or in complementary mode, whereby if one valve opens, the other closes by the same percentage. To achieve such behaviour, simply set the “valve” parameter (“Two EXV connected together”) and connect the valve motor power supply wires to the same connector. In the example shown below, for operation of valve B\_2 with valve B\_1 in complementary mode simply swap the connection of wires 1 and 3.

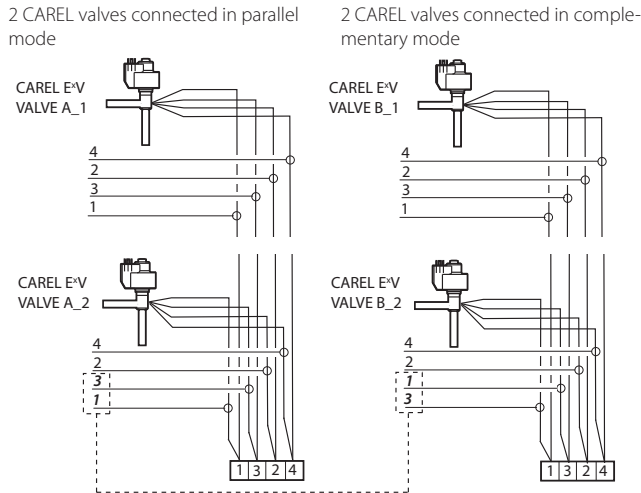

Fig. 2.h

**Note:** operation in parallel and complementary mode can only be used for CAREL valves, within the limits shown in the table below, where OK means that the valve can be used with all refrigerants at the rated operating pressure.

	CAREL valve model					
	E2V*	E3V*	E4V*	E5V*	E6V*	E7V*
Two EXVs connected together	OK	E3V45, MOPD = 35 bars E3V55, MOPD = 26 bars E3V65, MOPD = 20 bars	E4V85, MOPD = 22 bars E4V95, MOPD = 15 bars	NO	NO	NO

**Note:**

- MOPD = Maximum Operating-Pressure Differential
- The two CAREL ExV valves must be the same model (e.g. 2x E2V, 2x E3V, 2x E4V).

## 2.6 Shared pressure probe

Only 4 to 20 mA pressure probes (not ratiometric) can be shared. The probe can be shared by a maximum of 5 drivers. For multiplexed systems where controllers EVD evolution1 to EVD evolution5 share the same pressure probe, choose the normal option for EVD evolution1 and the “remote” option for the other drivers, up to the fifth. EVD evolution6 must use another pressure probe P2.

### EXAMPLE

	EVD Evolution1	to	EVD Evolution5	EVD Evolution6
Probe S1	-0.5 to 7 barg (P1)	to	remote, -0.5 to 7 barg	-0.5 to 7 barg (P2)

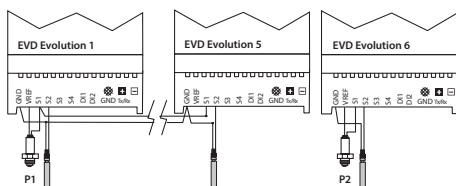

Fig. 2.i

Key:	P1	Shared pressure probe
	P2	Pressure probe

## 2.7 Connecting the module EVBAT00400

The EVBAT00400 module can close the valve in the event of power failures. Digital input 1/2 can be configured to detect the “Discharged battery” alarm.

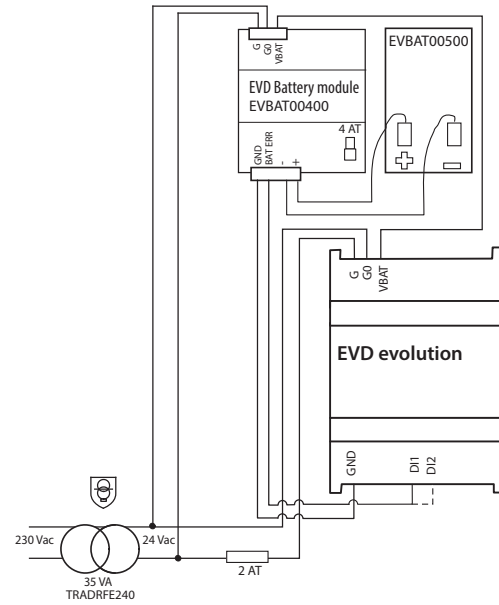

Fig. 2.j

**Note:** set the “Battery charge delay” parameter, depending on the application. See the chapter “Functions”.

## 2.8 Connecting the USB-tLAN converter

Procedure:

- remove the LED board cover by pressing on the fastening points;
- plug the adapter into the service serial port;
- connect the adapter to the converter and then this in turn to the computer.
- power up the driver.

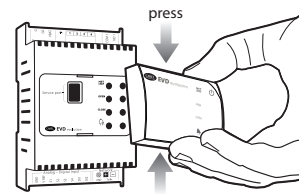

Fig. 2.k

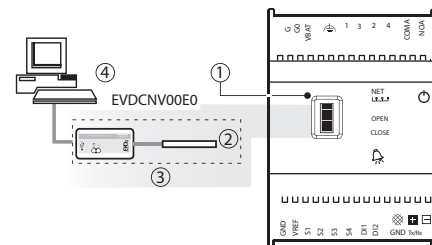

Fig. 2.l

Key:	1	service serial port adapter	3	USB/tLAN converter
	2	adapter	4	personal computer

**Note:** when using the service serial port connection, the VPM program can be used to configure the driver and update the driver and display firmware, downloadable from <http://ksa.carel.com>. See the appendix.

## 2.9 Connecting the USB/RS485 converter

Only on EVD evolution RS485/Modbus® models can the configuration computer be connected using the USB/RS485 converter and the serial port, according to the following diagram.

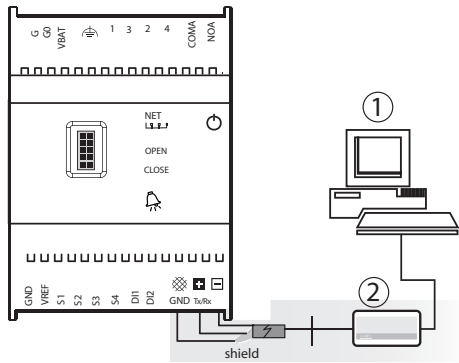

Fig. 2.m

Key:	1	personal computer for configuration
	2	USB/RS485 converter

**Note:**

- the serial port can be used for configuration with the VPM program and for updating the driver firmware, downloadable from <http://ksa.carel.com>;
- to save time, up to 8 EVD evolution drivers can be connected to the computer, updating the firmware at the same time (each driver must have a different network address).

## 2.10 Upload, Download and Reset parameters (display)

Procedure:

10. press the Help and Enter buttons together for 5 seconds;
  11. a multiple choice menu will be displayed, use UP/DOWN to select the required procedure;
  12. confirm by pressing ENTER;
  13. the display will prompt for confirmation, press ENTER;
  14. at the end a message will be shown to notify the operation if the operation was successful.
- UPLOAD: the display saves all the values of the parameters on the source driver;
  - DOWNLOAD: the display copies all the values of the parameters to the target driver;
  - RESET: all the parameters on the driver are restored to the default values. See the table of parameters in chapter 8.



Fig. 2.n

**Important:**

- the procedure must be carried out with driver powered;
- DO NOT remove the display from the driver during the UPLOAD, DOWNLOAD, RESET procedure;
- the parameters cannot be downloaded if the source driver and the target driver have incompatible firmware.

## 2.11 Show electrical connections (display)

To display the probe and valve electrical connections for drivers A and B, enter display mode. See paragraph 3.3.

## 2.12 General connection diagram

CASE 1:  
230 Vac power supply with emergency module

CASE 3:  
24 Vdc power supply

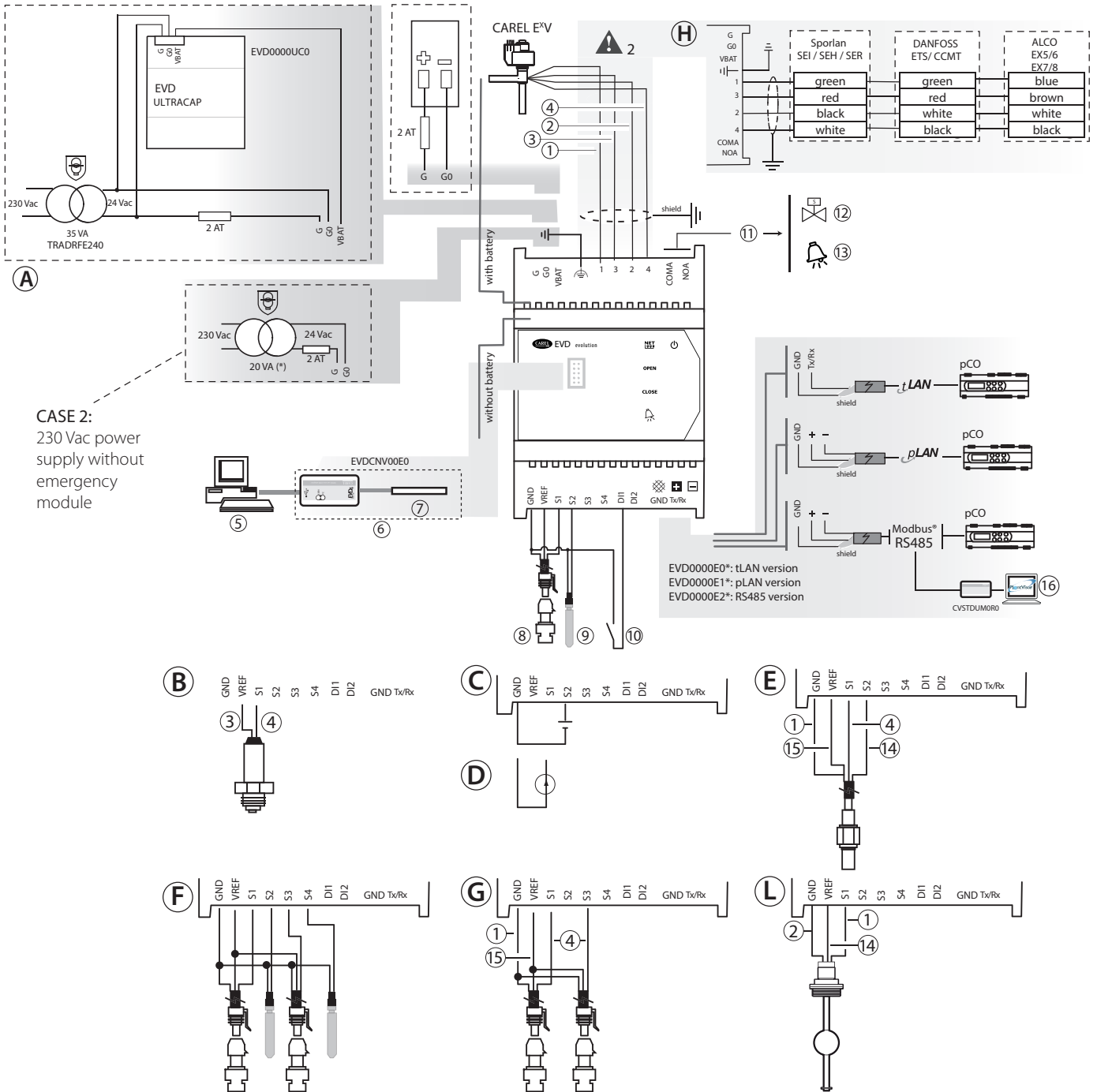

Fig. 2.0

**Key:**

- |                                   |                                                 |
|-----------------------------------|-------------------------------------------------|
| 1 green                           | 10 digital input 1 configured to enable control |
| 2 yellow                          | 11 free contact (up to 230 Vac)                 |
| 3 brown                           | 12 solenoid valve                               |
| 4 white                           | 13 alarm signal                                 |
| 5 configuration computer          | 14 red                                          |
| 6 USB/tLAN converter              | 15 black                                        |
| 7 adapter                         | 16 configuration/supervision computer           |
| 8 ratiometric pressure transducer |                                                 |
| 9 NTC probe                       |                                                 |

Note: for the configuration of the digital inputs see par. 6.3.

(\*): in combination with Alco EX7 or EX8 valves, use a 35 VA transformer code TRADRFE240.

- |     |                                                                                                                |
|-----|----------------------------------------------------------------------------------------------------------------|
| A   | Connection to EVD0000UC0                                                                                       |
| B   | Connection to electronic pressure probe (SPK**0000) or piezoresistive pressure transducer (SPKT00**CO)         |
| C   | Connection as positioner (0 to 10 Vdc input)                                                                   |
| D   | Connection as positioner (4 to 20 mA input)                                                                    |
| E   | Connection to combined pressure/temperature probe (SPKP00**TO)                                                 |
| F   | Connection to backup probes (S3, S4)                                                                           |
| G   | Ratiometric pressure transducer connections (SPKT00**RO)                                                       |
| H   | Connections of other types of valves                                                                           |
| L   | Connection to float level sensor (P/N LSR00*3000)                                                              |
| ⚠ 1 | The maximum length of the connection cable to the EVD0000UC0 module is 5 m.                                    |
| ⚠ 2 | The connection cable to the valve motor must be 4-wire shielded, AWG 22 with Lmax= 10 m, AWG 14 con Lmax= 50 m |

### 3. USER INTERFACE

The user interface consists of 5 LEDs that display the operating status, as shown in the table:

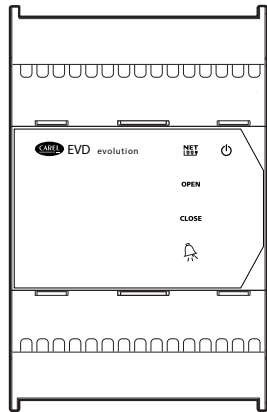

Fig. 3.a

LED	ON	OFF	Flashing
NET	Connection available	No connection	Communication error
OPEN	Opening valve	-	Driver disabled (*)
CLOSE	Closing valve	-	Driver disabled (*)
	Active alarm	-	-
	Driver powered	Driver not powered	Wrong power supply (see chap. Alarms)

Tab. 3.a

(\*) Awaiting completion of the initial configuration

#### 3.1 Assembling the display board (accessory)

The display board, once installed, is used to perform all the configuration and programming operations on the driver. It displays the operating status, the significant values for the type of control that the driver is performing (e.g. superheat control), the alarms, the status of the digital inputs and the relay output. Finally, it can save the configuration parameters for one driver and transfer them to a second driver (see the procedure for upload and download parameters).

For installation:

- remove the cover, pressing on the fastening points;
- fit the display board, as shown;
- the display will come on, and if the driver is being commissioned, the guided configuration procedure will start.

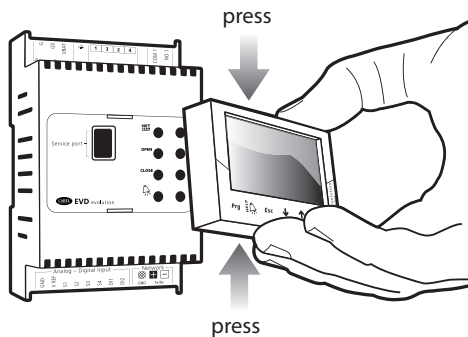

Fig. 3.b

**Important:** the driver is not activated if the configuration procedure has not been completed.

The front panel now holds the display and the keypad, made up of 6 buttons that, pressed alone or in combination, are used to perform all the configuration and programming operations on the driver.

#### 3.2 Display and keypad

The graphic display shows 2 system variables, the control status of the driver, the activation of the protectors, any alarms and the status of the relay output.

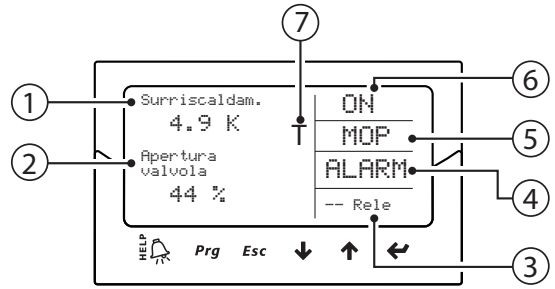

Fig. 3.c

Key:

1	1st variable displayed
2	2nd variable displayed
3	relay status
4	alarm (press "HELP")
5	protector activated
6	control status
7	adaptive control in progress

#### Display writings

	Control status	Protection active
ON	Operation	LowSH Low superheat
OFF	Standby	LOP Low evaporation temperature
POS	Positioning	MOP High evaporation temperature
WAIT	Wait	HiTcond High condensing temperature
CLOSE	Closing	
INIT	Valve motor error recognition procedure (*)	
TUN	Tuning in progress	

Tab. 3.b

(\*) The valve motor error recognition procedure can be disabled. See paragraph 9.5

#### Keypad

Button	Function
Prg	opens the screen for entering the password to access programming mode.
	<ul style="list-style-type: none"> <li>• if in alarm status, displays the alarm queue;</li> <li>• in the "Manufacturer" level, when scrolling the parameters, shows the explanation screens (Help).</li> </ul>
Esc	<ul style="list-style-type: none"> <li>• exits the Programming (Service/Manufacturer) and Display modes;</li> <li>• after setting a parameter, exits without saving the changes.</li> </ul>
↓ / ↑	<ul style="list-style-type: none"> <li>• navigates the display screens;</li> <li>• increases/decreases the value.</li> </ul>
UP / DOWN	
	<ul style="list-style-type: none"> <li>• switches from the display to parameter programming mode;</li> <li>• confirms the value and returns to the list of parameters.</li> </ul>
Enter	

Tab. 3.c

**Note:** the variables displayed as standard can be selected by configuring the parameters "Display main var. 1" and "Display main var. 2" accordingly. See the list of parameters.

### 3.3 Display mode (display)

Display mode is used to display the useful variables showing the operation of the system.

The variables displayed depend on the type of control selected.

1. press Esc one or more times to switch to the standard display;
2. press UP/DOWN: the display shows a graph of the superheat, the percentage of valve opening, the evaporation pressure and temperature and the suction temperature variables;
3. press UP/DOWN: the variables are shown on the display, followed by the screens with the probe and valve motor electrical connections;
4. press Esc to exit display mode.

For the complete list of the variables shown on the display, see the chapter: "Table of parameters".

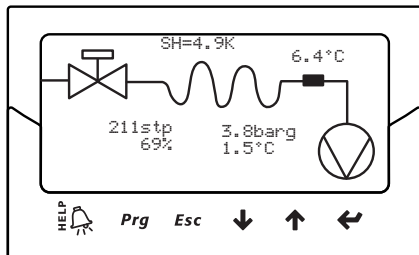

Fig. 3.d

### 3.4 Programming mode (display)

The parameters can be modified using the front keypad. Access differs according to the user level: Service (Installer) and manufacturer.

#### Modifying the Service parameters

The Service parameters, as well as the parameters for commissioning the driver, also include those for the configuration of the inputs, the relay output, the superheat set point or the type of control in general, and the protection thresholds. See the table of parameters.

Procedure:

1. press Esc one or more times to switch to the standard display;
2. press Prg: the display shows a screen with the PASSWORD request;
3. press ENTER and enter the **password for the Service level: 22**, starting from the right-most figure and confirming each figure with ENTER;
4. if the value entered is correct, the first modifiable parameter is displayed, network address;
5. press UP/DOWN to select the parameter to be set;
6. press ENTER to move to the value of the parameter;
7. press UP/DOWN to modify the value;
8. press ENTER to save the new value of the parameter;
9. repeat steps 5, 6, 7, 8 to modify the other parameters;
10. press Esc to exit the procedure for modifying the Service parameters.



Fig. 3.e

#### Note:

- if when setting a parameter the value entered is out-of-range, this is not accepted and the parameter soon after returns to the previous value;
- if no button is pressed, after 5 min the display automatically returns to the standard mode;
- to set a negative value move to the left-most digit and press Up/Down.

#### Modifying the Manufacturer parameters

The Manufacturer level is used to configure all the driver parameters, and consequently, in addition to the Service parameters, the parameters relating to alarm management, the probes and the configuration of the valve. See the table of parameters.

Procedure:

1. press Esc one or more times to switch to the standard display;
2. press Prg: the display shows a screen with the PASSWORD request;
3. press ENTER and enter the Manufacturer level password: 66, starting from the right-most figure and confirming each figure with ENTER;
4. if the value entered is correct, the list of parameter categories is shown:
  - Configuration
  - Probes
  - Control
  - Special
  - Alarm configuration
  - Valve
5. press the UP/DOWN buttons to select the category and ENTER to access the first parameter in the category;
6. press UP/DOWN to select the parameter to be set and ENTER to move to the value of the parameter;
7. press UP/DOWN to modify the value;
8. press ENTER to save the new value of the parameter;
9. repeat steps 6, 7, 8 to modify the other parameters;
10. press Esc to exit the procedure for modifying the Manufacturer parameters.

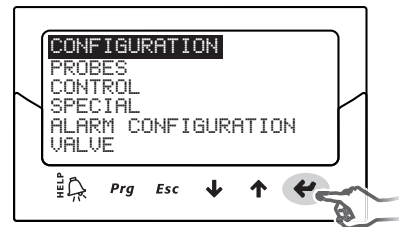

Fig. 3.f

#### Note:

- all the driver parameters can be modified by entering the Manufacturer level;
- if when setting a parameter the value entered is out-of-range, this is not accepted and the parameter soon after returns to the previous value;
- if no button is pressed, after 5 min the display automatically returns to the standard mode.

## 4. COMMISSIONING

**! Important:** if the refrigerant is not available among the refrigerant parameter options, contact CAREL service to:

- confirm that the system: pCO controller + CAREL electronic expansion valve is compatible with the desired refrigerant (custom);
- identify the values that define the custom refrigerant and enter them for parameters: "Dew a...f high/low" and "Bubble a...f high/low". See the parameter table.

### 4.1 Commissioning

Once the electrical connections have been completed (see the chapter on installation) and the power supply has been connected, the operations required for commissioning the driver depend on the type of interface used, however essentially involve setting just 4 parameters: refrigerant, valve, type of pressure probe S1 and type of main control.

Types of interfaces:

- DISPLAY:** after having correctly configured the setup parameters, confirmation will be requested. Only after confirmation will the driver be enabled for operation, the main screen will be shown on the display and control will be able to commence when requested by the pCO controller via LAN or when digital input DI1/DI2 closes. See paragraph 4.2;
- VPM:** to enable control of the driver via VPM, set "Enable EVD control" to 1; this is included in the safety parameters, in the special parameters menu, under the corresponding access level. However, the setup parameters should first be set in the related menu. The driver will then be enabled for operation and control will be able to commence when requested by the pCO controller via LAN or when digital input DI1/DI2 closes. If due to error or for any other reason "Enable EVD control" should be set to 0 (zero), the driver will immediately stop control and will remain in standby until re-enabled, with the valve stopped in the last position;
- SUPERVISOR:** to simplify the commissioning of a considerable number of drivers using the supervisor, the setup operation on the display can be limited to simply setting the network address. The display will then be able to be removed and the configuration procedure postponed to a later stage using the supervisor or, if necessary, reconnecting the display. To enable control of the driver via supervisor, set "Enable EVD control"; this is included in the safety parameters, in the special parameters menu, under the corresponding access level. However, the setup parameters should first be set in the related menu. The driver will then be enabled for operation and control will be able to commence when requested by the pCO controller via pLAN or when digital input DI1/DI2 closes. As highlighted on the supervisor, inside of the yellow information field relating to the "Enable EVD control" parameter, if due to error or for any other reason "Enable EVD control" should be set to 0 (zero), the driver will immediately stop control and will remain in standby until re-enabled, with the valve stopped in the last position;
- pCO PROGRAMMABLE CONTROLLER:** the first operation to be performed, if necessary, is to set the network address using the display.

**! Important:** for the driver with pLAN serial port, see the guidelines described in the following paragraph for setting the address.

If a pLAN, tLAN or RS485/Modbus® driver is used, connected to a pCO family controller, the setup parameters will not need to be set and confirmed. In fact, the application running on the pCO will manage the correct values based on the unit controlled. Consequently, simply set the pLAN, tLAN or RS485/Modbus® address for the driver as required by the application on the pCO, and after a few seconds communication will commence between the two instruments and the driver automatically be enabled for control. The main screen will shown on the display, which can then be removed, and control will be able to commence when requested by the pCO controller or digital input DI1/DI2. If there is no communication between the pCO and the driver (see the paragraph "LAN error alarm"), the driver will be able to continue control based on the status of digital input DI1/DI2. See par. 6.3.

### 4.2 Setting the pLAN network address

The pLAN addresses of the devices in the network must be assigned according to the following rule:  
the EVD Evolution driver addresses must be assigned in increasing order from left to right, starting with the controllers (A), then the drivers (B) and finally the terminals (C).

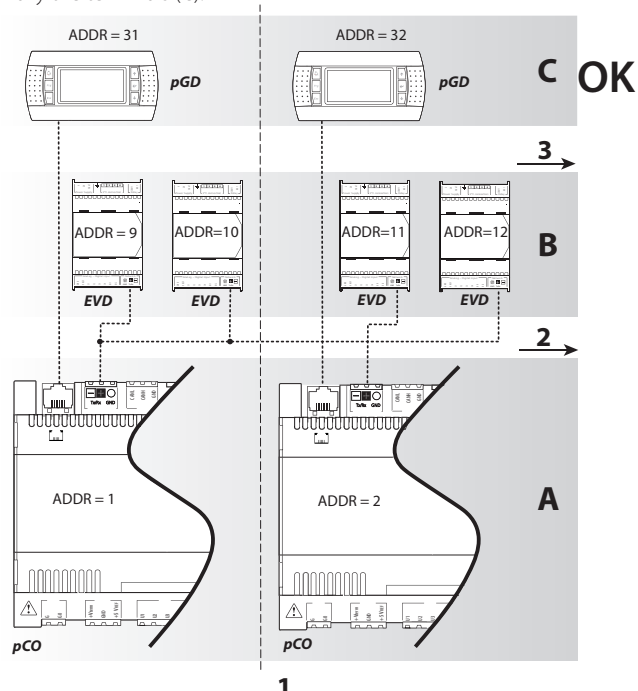

Fig. 4.a

**! Important:** if the addresses are not assigned in this way, as for example shown in the following figure, malfunctions will occur if one of the pCO controllers is offline.

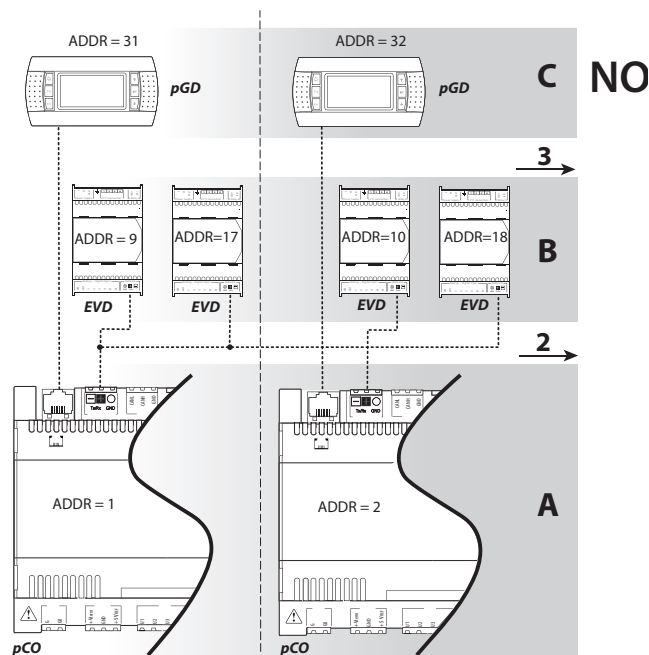
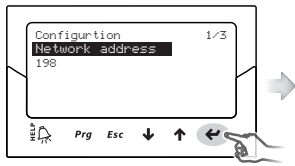

Fig. 4.b

### 4.3 Guided commissioning procedure (display)

After having fitted the display:



- 1 the first parameter is displayed: network address;
- 2 press Enter to move to the value of the parameter

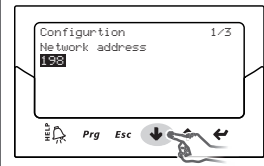

- 3 press UP/DOWN to modify the value

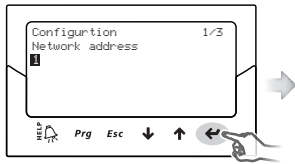

- 4 press Enter to confirm the value

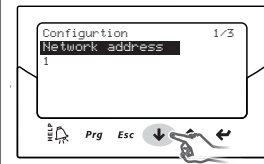

- 5 press UP/DOWN to move to the next parameter, refrigerant

- 6 repeat steps 2, 3, 4, 5 to modify the values of the parameters: refrigerant, valve, pressure probe S1, main regulation;

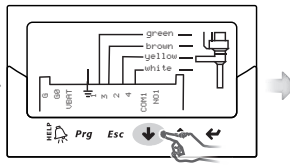
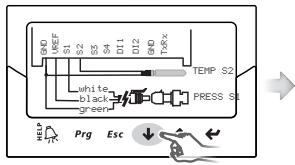

- 7 check that the electrical connections are correct;

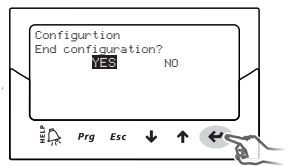

- 8 if the configuration is correct exit the procedure, otherwise choose NO and return to step 2;

At the end of the configuration procedure the controller activates the valve motor error recognition procedure, showing "INIT" on the display. See paragraph 9.5

To simplify commissioning and avoid possible malfunctions, the driver will not start until the following have been configured:

1. network address;
2. refrigerant;
3. valve;
4. pressure probe S1;
5. type of main control, that is, the type of unit the superheat control is applied to.

**Note:**

- to exit the guided commissioning procedure press the DOWN button repeatedly and finally confirm that configuration has been completed. The guided procedure CANNOT be ended by pressing Esc;
- if the configuration procedure ends with a configuration error, access Service parameter programming mode and modify the value of the parameter in question;
- if the valve and/or the pressure probe used are not available in the list, select any model and end the procedure. Then the driver will be enabled for control, and it will be possible to enter Manufacturer programming mode and set the corresponding parameters manually.

**Important:** for 24 Vdc power supply, at the end of the guided commissioning procedure, to start control set "Power supply mode" parameter=1, otherwise the valve remains in the closed position. See paragraph 6.1.

### Network address

The network address assigns to the driver an address for the serial connection to a supervisory system via RS485, and to a pCO controller via pLAN, tLAN, RS485/Modbus®.

Parameter/description	Def.	Min.	Max.	UOM
<b>CONFIGURATION</b>				
Network address	pLAN: 30 others: 198	1	207	-

Tab. 4.d

For network connection of the RS485/Modbus® models the communication speed also needs to be set, in bits per second, using the parameter "Network settings". See paragraph 6.2.

### Refrigerant

The type of refrigerant is essential for calculating the superheat. In addition, it is used to calculate the evaporation and condensing temperature based on the reading of the pressure probe.

Parameter/description	Def.
<b>CONFIGURATION</b>	
Refrigerant:	R404A
0= custom; 1= R22; 2= R134a; 3= R404A; 4= R407C; 5= R410A; 6= R507A; 7= R290; 8= R600; 9= R600a; 10= R717; 11= R744; 12= R728; 13= R1270; 14= R417A; 15= R422D; 16= R413A; 17= R422A; 18= R423A; 19= R407A; 20= R427A; 21=R245Fa; 22=R407F; 23=R32; 24=HTR01 ; 25=HTR02; 26=R23; 27 = R1234yf; 28 = R1234ze; 29 = R455A; 30 = R170; 31 = R442A; 32 = R447A; 33 = R448A; 34 = R449A; 35 = R450A; 36 = R452A; 37 = R508B; 38 = R452B; 39 = R513A; 40 = R454B; 41 = R458A; 42 = R407H; 43 = R454A; 44 = R454C; 45 = R470A; 46 = R515B; 47 = R466A	

Tab. 4.e

**Note:**

- for CO<sub>2</sub> cascade systems, at the end of the commissioning procedure also set the auxiliary refrigerant. See the following paragraph.
- if the refrigerant is not among those available for the "Refrigerant" parameter:
  1. set any refrigerant (e.g. R404);
  2. select the model of valve, the pressure probe S1, the type of main control and end the commissioning procedure;
  3. enter programming mode and set the type of refrigerant: custom, and the parameters "Dew a...f high/low" and "Bubble a...f high/low" that define the refrigerant;
  4. start control, for example by closing the digital input contact to enable operation.

### Valve

Setting the type of valve automatically defines all the control parameters based on the manufacturer's data for each model.

In Manufacturer programming mode, the control parameters can then be fully customised if the valve used is not in the standard list. In this case, the driver will detect the modification and indicate the type of valve as "Customised".

Parameter/description	Def.
<b>CONFIGURATION</b>	
Valve:	CAREL
0=custom ; 1= CAREL E <sup>V</sup> ; 2= Alco EX4; 3= Alco EX5; 4= Alco EX6; 5= Alco EX7; 6= Alco EX8 330Hz suggested by CAREL; 7= Alco EX8 500Hz specified by Alco; 8=Sporlan SEI 0.5-11; 9= Sporlan SER 1.5-20; 10= Sporlan SEI 30; 11= Sporlan SEI 50; 12= Sporlan SEH 100; 13= Sporlan SEH 175; 14= Danfoss ETS 12.5-25B; 15= Danfoss ETS 50B; 16= Danfoss ETS 100B; 17= Danfoss ETS 250; 18= Danfoss ETS 400; 19= two CAREL E <sup>V</sup> connected together 20= Sporlan Ser(I)G, J, K; 21= Danfoss CCM 10-20-30; 22= Danfoss CCM 40; 23=Danfoss CCMT 2-4-8; 24 = Disabled; 25= CAREL Ejector E2J17A-S1N0; 26= CAREL Ejector E2J23AT1N0; 27= CAREL Ejector E3J26AT2N0; 28= CAREL Ejector E3J33AU2N0; 29= CAREL Ejector E3J39AV3N0; 30= CAREL Ejector E6J50AV3N0; 31= Danfoss CCMT 16; 32= Danfoss CCMT 24; 33= Danfoss CCMT 30; 34= Danfoss CCMT 42; 35= Danfoss Colibri	

Tab. 4.f

**Note:**

- select Valve = disabled if Main control = I/O expansion for pCO to prevent the EEV motor error from being displayed. I/O expansion for pCO control can be selected at the end of the commissioning procedure, by entering programming mode.

**Important:**

- two CAREL E<sup>x</sup>V valves connected together must be selected if two CAREL E<sup>x</sup>V valves are connected to the same terminal, to have parallel or complementary operation;
- as described, control is only possible with CAREL E<sup>x</sup>V valves;
- not all CAREL valves can be connected: see paragraph 2.5.

**Pressure/refrigerant level probe S1**

Setting the type of pressure probe S1 defines the range of measurement and the alarm limits based on the manufacturer's data for each model, usually indicated on the rating plate on the probe.

Select "CAREL liquid level" and connect the CAREL float level sensor to manage the following functions:

- evaporator liquid level control with CAREL sensor;
- condenser liquid level control with CAREL sensor.

See the chapter on "Control"

Parameter/description	Def.
<b>CONFIGURATION</b>	
Sensor S1	Ratiom.:
Ratiometric (OUT=0 to 5V)	Electronic (OUT=4 to 20mA)
1= -1 to 4.2 barg	8= -0.5 to 7 barg
2= -0.4 to 9.3 barg	9= 0 to 10 barg
3= -1 to 9.3 barg	10= 0 to 18,2 barg
4= 0 to 17.3 barg	11= 0 to 25 barg
5= 0.85 to 34.2 barg	12= 0 to 30 barg
6= 0 to 34.5 barg	13= 0 to 44.8 barg
7= 0 to 45 barg	14= remote, -0.5 to 7 barg
	15= remote, 0 to 10 barg
	16= remote, 0 to 18,2 barg
	17= remote, 0 to 25 barg
	18= remote, 0 to 30 barg
	19= remote, 0 to 44.8 barg
	20= external signal (4 to 20 mA)
21= -1 to 12.8 barg	
22= 0 to 20.7 barg	
23= 1.86 to 43.0 barg	
24 = CAREL liquid level	
25 = 0...60,0 barg	
26 = 0...90,0 barg	
27= external signal (0 to 5 V)(*)	

Tab. 4.g

(\*) for programmable positioner. See chapter "Control".

**Important:** in case two pressure probes are installed S1 and S3, they must be of the same type. It is not allowed to use a ratiometric probe and an electronic one.

**Note:** in the case of multiplexed systems where the same pressure probe is shared between multiple drivers, choose the normal option for the first driver and the "remote" option for the remaining drivers. The same pressure transducer can be shared between a maximum of 5 drivers.

Example: to use the same pressure probe, -0.5 to 7 bars, for 3 drivers

For the first driver, select: -0.5 to 7 barg

For the second and third driver select: **remote** -0.5 to 7 barg.

See paragraph 2.6

**Note:**

- the range of measurement by default is always in bar gauge (barg). In the manufacturer menu, the parameters corresponding to the range of measurement and the alarms can be customised if the probe used is not in the standard list. If modifying the range of measurement, the driver will detect the modification and indicate the type of probe S1 as "Customised".
- The software on the driver takes into consideration the unit of measure. If a range of measurement is selected and then the unit of measure is changed (from bars to psi), the driver automatically updates in limits of the range of measurement and the alarm limits. BY default, the main control probe S2 is set as "CAREL NTC". Other types of probes can be selected in the service menu.
- Unlike the pressure probes, the temperature probes do not have any modifiable parameters relating to the range of measurement, and consequently only the models indicated in the list can be used (see the chapter on "Functions" and the list of parameters). In any case, in manufacturer programming mode, the limits for the probe alarm signal can be customised.

**Main control**

Setting the main control defines the operating mode of the driver.

Parameter/description	Def.
<b>CONFIGURATION</b>	
Main control	multiplexed cabinet/cold room
<b>Superheat control</b>	
1= multiplexed cabinet/cold room	multiplexed cabinet/cold room
2= cabinet/cold room with on-board compressor	
3= "perturbed" cabinet/cold room	
4= cabinet/cold room with subcritical CO <sub>2</sub>	
5= R404A condenser for subcritical CO <sub>2</sub>	
6= air-conditioner/chiller with plate heat exchanger	
7= air-conditioner/chiller with tube bundle heat exchanger	
8= air-conditioner/chiller with finned coil heat exchanger	
9= air-conditioner/chiller with variable cooling capacity	
10= "perturbed" air-conditioner/chiller	
<b>Advanced control</b>	
11= EPR back pressure	
12= hot gas bypass by pressure	
13= hot gas bypass by temperature	
14= transcritical CO <sub>2</sub> tqas cooler	
15= analogue positioner (4 to 20 mA)	
16= analogue positioner (0 to 10 V)	
17= air-conditioner/chiller or cabinet/cold room with adaptive control	
18= air-conditioner/chiller with digital scroll compressor	
19= AC/chiller with BLDC scroll compressor(*)	
20= superheat control with 2 temperature probes	
21= I/O expansion for pCO	
22= Programmable SH control	
23= Programmable special control	
24= Programmable positioner	
25= Evaporator liquid level control with CAREL sensor	
26= Condenser liquid level control with CAREL sensor	

Tab. 4.h

(\*) CAREL valve drivers only

The superheat set point and all the parameters corresponding to PID control, the operation of the protectors and the meaning and use of probes S1 and/or S2 will be automatically set to the values recommended by CAREL based on the selected application.

During this initial configuration phase, only superheat control mode from 1 to 10 can be set, which differ based on the application (chiller, refrigerated cabinet, etc.).

In the event of errors in the initial configuration, these parameters can later be accessed and modified inside the service or manufacturer menu. If the driver default parameters are restored (RESET procedure, see the chapter on Installation), when next started the display will again show the guided commissioning procedure.

## 4.4 Auxiliary refrigerant

In the event of cascade systems comprising a main circuit and a secondary circuit, the auxiliary refrigerant is the refrigerant in the secondary circuit. See the paragraphs "Auxiliary control" and "Reverse high condensing temperature protection (HiTcond) on S3". The default value 0 sets the same refrigerant as in the main circuit.

### Parameter/description

Configuration	Def.	Min	Max	UOM
Auxiliary refrigerant	0	-	-	-
-1=custom; 0 = same as main circuit;				
1=R22 ; 2=R134a; 3=R404A; 4=R407C;				
5=R410A; 6=R507A; 7=R290; 8=R600;				
9=R600a; 10=R717; 11=R744; 12=R728;				
13=R1270; 14=R417A; 15=R422D;				
16=R413A; 17=R422A; 18=R423A;				
19=R407A; 20=R427A; 21=R245FA;				
22=R407F; 23=R32; 24=HTR01 ; 25=HTR02; 26= R3;				
1=R22 ; 2=R134a; 3=R404A; 4=R407C; 5=R410A;				
6=R507A; 7=R290; 8=R600; 9=R600a; 10=R717;				
11=R744; 12=R728; 13=R1270; 14=R417A;				
15=R422D; 16=R413A; 17=R422A; 18=R423A;				
19=R407A; 20=R427A; 21=R245FA; 22=R407F;				
23=R32; 24=HTR01; 25=HTR02; 26= R3; 27 =				
R1234yf; 28 = R1234ze; 29 = R455A; 30 = R170;				
31 = R442A; 32 = R447A; 33 = R448A;				
34 = R449A; 35 = R450A; 36 = R452A;				
37 = R508B; 38 = R452B; 39 = R513A;				
40 = R454B; 41 = R458A; 42 = R407H; 43 = R454A;				
44 = R454C; 45 = R470A; 46 = R515B; 47 = R466A				

Tab. 4.i



### Note:

- if main refrigerant= custom and secondary refrigerant = custom, the secondary refrigerant is the same as the main refrigerant, defined by parameters dew a...f high/low and bubble a...f high/low;
- if main refrigerant is selected between 1 and 26 and secondary refrigerant= custom, the secondary refrigerant parameters will be those pertaining to the custom refrigerant: "Dew a...f high/low" and "Bubble a...f high/low".

## 4.5 Checks after commissioning

After commissioning:

- check that the valve completes a full closing cycle to perform alignment;
- set, if necessary, in Service or Manufacturer programming mode, the superheat set point (otherwise keep the value recommended by CAREL based on the application) and the protection thresholds (LOP, MOP, etc.). See the chapter on Protectors.

## 4.6 Other functions

By entering Service programming mode, other types of main control can be selected (transcritical CO<sub>2</sub>, hot gas bypass, etc.), as well as so-called advanced control functions, which do not involve the superheat, activating auxiliary controls that use probes S3 and/or S4 and setting the suitable values for the control set point and the LowSH, LOP and MOP protection thresholds (see the chapter on "Protectors"), which depend on the specific characteristics of the unit controlled.

By entering Manufacturer programming mode, finally, the operation of the driver can be completely customised, setting the function of each parameter. If the parameters corresponding to PID control are modified, the driver will detect the modification and indicate the main control as "Customised".

## 5. CONTROL

### 5.1 Main and auxiliary control

EVD evolution features two types of control: **main** and **auxiliary**. Main control is always active, while auxiliary control can be activated by parameter. Main control defines the operating mode of the driver. The first 10 settings refer to superheat control, the others are so-called “special” settings and are pressure or temperature settings or depend on a control signal from an external controller. The last advanced functions (18, 19, 20) also relate to superheat control. Programmable control exploits CAREL’s technology and know-how in terms of control logic. Finally, it is possible to control liquid level in applications with flooded evaporator/condenser.

Parameter/description	Def.
<b>CONFIGURATION</b>	
Main control	multi-plexed
<b>Superheat control</b>	
1= multiplexed cabinet/cold room	cabinet/
2= cabinet/cold room with on-board compressor	cold room
3= “perturbed” cabinet/cold room	
4= cabinet/cold room with subcritical CO <sub>2</sub>	
5= R404A condenser for subcritical CO <sub>2</sub>	
6= air-conditioner/chiller with plate heat exchanger	
7= air-conditioner/chiller with tube bundle heat exchanger	
8= air-conditioner/chiller with finned coil heat exchanger	
9= air-conditioner/chiller with variable cooling capacity	
10= “perturbed” air-conditioner/chiller	
<b>Advanced control</b>	
11= EPR back pressure	
12= hot gas bypass by pressure	
13= hot gas bypass by temperature	
14= gas cooler CO <sub>2</sub> transcritical	
15= analogue positioner (4 to 20 mA)	
16= analogue positioner (0 to 10 V)	
<b>Superheat control</b>	
17= air-conditioner/chiller or cabinet/ cold room with adaptive control	
18= air-conditioner/chiller with digital scroll compressor	
19= AC/chiller with BLDC scroll compressor(*)	
20= superheat control with 2 temperature probes	
<b>Advanced control</b>	
21= I/O expansion for pCO	
22= Programmable SH control	
23= Programmable special control	
24= Programmable positioner	
25= Evaporator liquid level control with CAREL sensor	
26= Condenser liquid level control with CAREL sensor	

Tab. 5.a

(\*) only for CAREL valve drivers

**Note:**

- R404A condensers with subcritical CO<sub>2</sub> refer to superheat control for valves installed in cascading systems where the flow of R404A (or other refrigerant) in an exchanger acting as the CO<sub>2</sub> condenser needs to be controlled;
- perturbed cabinet/cold room or air-conditioner/chiller refer to units that momentarily or permanently operate with swinging condensing or evaporation pressure.

Auxiliary control features the following settings:

Parameter/description	Def.
<b>CONFIGURATION</b>	
Auxiliary control	Disabled
1=Disabled	
2=High condensing temperature protection on S3 probe	
3=Modulating thermostat on S4 probe	
4=Backup probes on S3 & S4	
5=Reserved	
6=Reserved	
7=Reserved	
8=Subcooling measurement	
9=Reverse high condensing temp. protection on S3	

Tab. 5.b

**Important:** the “High condensing temperature protection” and “Modulating thermostat” auxiliary settings can only be enabled if the main control is also superheat control with settings 1 to 10 and 17, 18. On the other hand, the “Backup probes on S3 and S4” auxiliary control can be activated, once the corresponding probes have been connected, only for settings from 1 to 18.

The following paragraphs explain all the types of control that can be set on EVD evolution.

### 5.2 Superheat control

The primary purpose of the electronic valve is ensure that the flow-rate of refrigerant that flows through the nozzle corresponds to the flow-rate required by the compressor. In this way, the evaporation process will take place along the entire length of the evaporator and there will be no liquid at the outlet and consequently in the branch that runs to the compressor. As liquid is not compressible, it may cause damage to the compressor and even breakage if the quantity is considerable and the situation lasts some time.

#### Superheat control

The parameter that the control of the electronic valve is based on is the superheat temperature, which effectively tells whether or not there is liquid at the end of the evaporator. The superheat temperature is calculated as the difference between: superheated gas temperature (measured by a temperature probe located at the end of the evaporator) and the saturated evaporation temperature (calculated based on the reading of a pressure transducer located at the end of the evaporator and using the Tsat(P) conversion curve for each refrigerant).

$$\text{Superheat} = \text{Superheated gas temperature } (*) - \text{Saturated evaporation temperature } (*)$$

(\*) suction

If the superheat temperature is high it means that the evaporation process is completed well before the end of the evaporator, and therefore flow-rate of refrigerant through the valve is insufficient. This causes a reduction in cooling efficiency due to the failure to exploit part of the evaporator. The valve must therefore be opened further. Vice-versa, if the superheat temperature is low it means that the evaporation process has not concluded at the end of the evaporator and a certain quantity of liquid will still be present at the inlet to the compressor. The valve must therefore be closed further. The operating range of the superheat temperature is limited at the lower end: if the flow-rate through the valve is excessive the superheat measured will be near 0 K. This indicates the presence of liquid, even if the percentage of this relative to the gas cannot be quantified. There is therefore an undetermined risk to the compressor that must be avoided. Moreover, a high superheat temperature as mentioned corresponds to an insufficient flow-rate of refrigerant. The superheat temperature must therefore always be greater than 0 K and have a minimum stable value allowed by the valve-unit system. A low superheat temperature in fact corresponds to a situation of probable instability due to the turbulent evaporation process approaching the measurement point of the probes. The expansion valve must therefore be controlled with extreme precision and a reaction capacity around the superheat set point, which will almost always vary from 3 to 14 K. Set point values outside of this range are quite infrequent and relate to special applications.

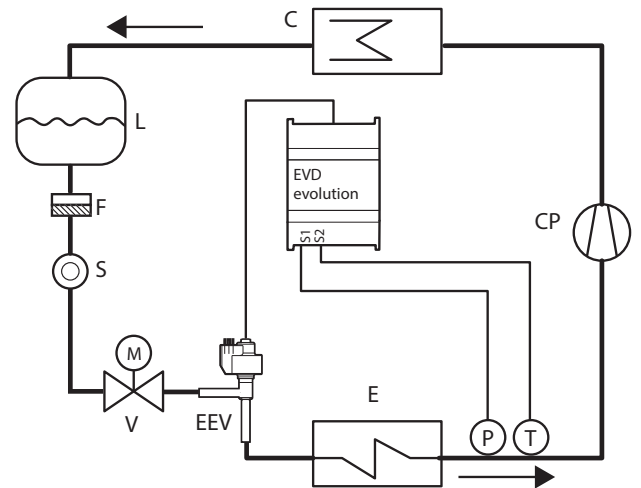

Fig. 5.a

Key:

CP	compressor	EEV	electronic expansion valve
C	condenser	V	solenoid valve
L	liquid receiver	E	evaporator
F	dewatering filter	P	pressure probe (transducer)
S	liquid indicator	T	temperature probe

For the wiring, see paragraph "General connection diagram".



**Note:** superheat control in a refrigerant circuit with BLDC compressor requires two probes for superheat control and two probes downstream of the compressor for discharge superheat and discharge temperature control. See par. 5.5.

**PID parameters**

Superheat control, as for any other mode that can be selected with the "main control" parameter, is performed using PID control, which in its simplest form is defined by the law:

$$u(t) = K \left( e(t) + \frac{1}{T_i} \int e(t) dt + T_d \frac{de(t)}{dt} \right)$$

Key:

u(t)	Valve position	Ti	Integration time
e(t)	Error	Td	Derivative time
K	Proportional gain		

Note that regulation is calculated as the sum of three separate contributions: proportional, integral and derivative.

- the proportional action opens or closes the valve proportionally to the variation in the superheat temperature. Thus the greater the K (**proportional gain**) the higher the response speed of the valve. The proportional action does not consider the superheat set point, but rather only reacts to variations. Therefore if the superheat value does not vary significantly, the valve will essentially remain stationary and the set point cannot be reached;
- the integral action is linked to time and moves the valve in proportion to the deviation of the superheat value from the set point. The greater the deviations, the more intense the integral action; in addition, the lower the value of T (**integration time**), the more intense the action will be. The integration time, in summary, represents the intensity of the reaction of the valve, especially when the superheat value is not near the set point;
- the derivative action is linked to the speed of variation of the superheat value, that is, the gradient at which the superheat changes from instant to instant. It tends to react to any sudden variations, bringing forward the corrective action, and its intensity depends on the value of the time Td (**derivative time**).

Parameter/description	Def.	Min.	Max.	UOM
<b>CONTROL</b>				
Superheat set point	11	LowSH: t.hold	180 (320)	K (°F)
PID proport. gain	15	0	800	-
PID integration time	150	0	1000	s
PID derivative time	5	0	800	s

Tab. 5.c

See the "EEV system guide" +030220810 for further information on calibrating PID control.



**Note:** when selecting the type of main control (both superheat control and special modes), the PID control values suggested by CAREL will be automatically set for each application.

**Protector control parameters**

See the chapter on "Protectors". Note that the protection thresholds are set by the installer/manufacturer, while the times are automatically set based on the PID control values suggested by CAREL for each application.

Parameter/description	Def.	Min.	Max.	UOM
<b>CONTROL</b>				
LowSH protection threshold	5	-40 (-72)	superh. set K(°F) point.	
LowSH protection integration time	15	0	800	s
LOP protection threshold	-50	-60 (-76)	MOP threshold	°C(°F)
LOP protection integration time	0	0	800	s
MOP protection threshold	50	LOP threshold	200 (392)	°C(°F)
MOP protection integration time	20	0	800	s
<b>ADVANCED</b>				
High Tcond threshold	80	-60 (-76)	200 (392)	°C (°F)
High Tcond integration time	20	0	800	s

Tab. 5.d

**5.3 Control with Emerson Climate Digital Scroll™ compressor**



**Important:** this type of control is incompatible with adaptive control and autotuning.

Digital Scroll compressors allow wide modulation of cooling capacity by using a solenoid valve to active a patented refrigerant bypass mechanism. This operation nonetheless causes swings in the pressure of the unit, which may be amplified by normal control of the expansion valve, leading to malfunctions. Dedicated control ensures greater stability and efficiency of the entire unit by controlling the valve and limiting swings based on the instant compressor modulation status. To be able to use this mode, the pLAN version driver must be connected to a Carel pCO series controller running a special application to manage units with Digital scroll compressors.

Parameter/Description	Def.
<b>CONFIGURATION</b>	
Main control	multiplexed cabinet/cold room
...	
air-conditioner/chiller with Digital Scroll compressor	

Tab. 5.e

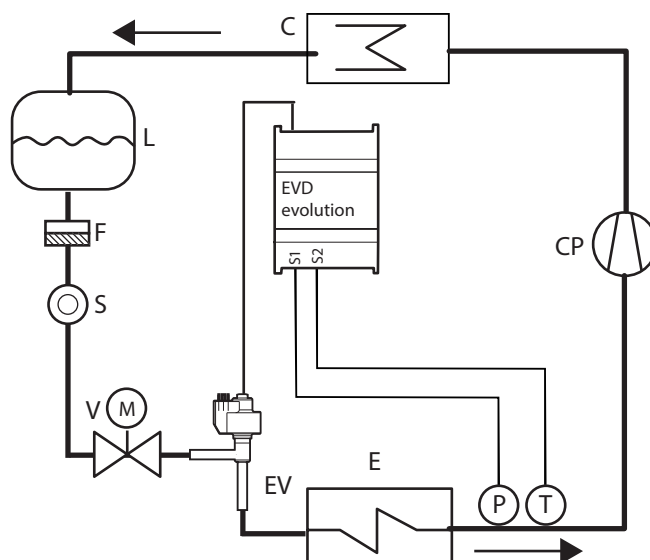

Fig. 5.b

Key:

CP	Compressor	V	Solenoid valve
C	Condenser	T	Temperature probe
L	Liquid receiver	EV	Electronic valve
F	Dewatering filter	E	Evaporator
S	Liquid gauge	P	Pressure probe

For information on the wiring see paragraph "General connection diagram".

### 5.4 BLDC Control with compressor

**⚠ Important:** this type of control is incompatible with adaptive control and autotuning.

To be able to use this control function, only available for CAREL valve drivers, the driver must be connected to a CAREL pCO programmable controller running an application able to manage a unit with BLDC scroll compressor. In addition, the compressor must be controlled by the CAREL Power+ "speed drive" (with inverter), specially designed to manage the speed profile required by the compressor operating specifications. Two probes are needed for superheat control (PA, TA) plus two probes located downstream of the compressor (PB, TB) for discharge superheat and discharge temperature (TB) control.

Parameter/Description	Def.
CONFIGURATION	
Main control	multiplexed showcase/cold room
...	
AC/chiller with BLDC compressor	

Tab. 5.f

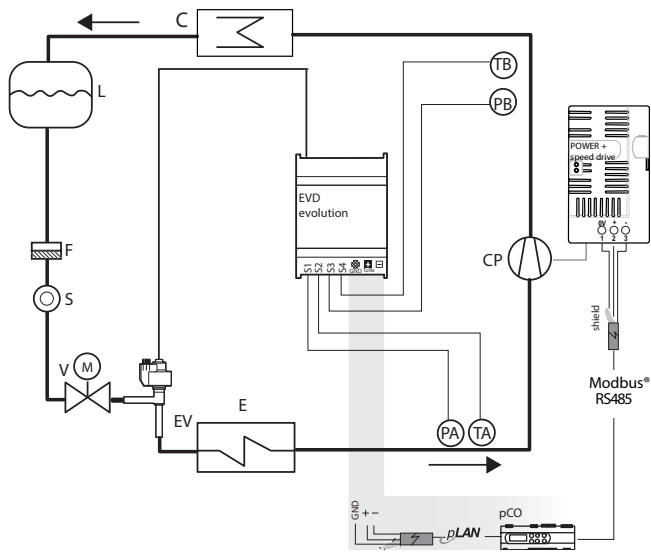

Fig. 5.c

Key:

CP	Compressor	V	Solenoid valve
C	Condenser	S	Liquid gauge
L	Liquid receiver	EV	Electronic valve
F	Dewatering filter	E	Evaporator
TA, TB	Temperature probes	PA, PB	Pressure probes

For information on the wiring see paragraph "General connection diagram".

To optimise performance of the refrigerant circuit, compressor operation must always be inside a specific area, called the envelope, defined by the compressor manufacturer.

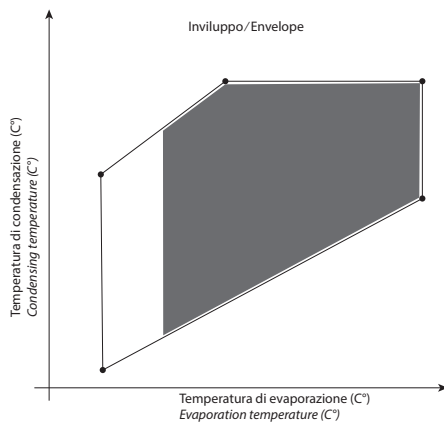

Fig. 5.d

The pCO controller defines the current set point according to the point of operation within the envelope:

- superheat setpoint;
- discharge superheat setpoint;
- discharge temperature setpoint.

Parameter/Description	Def.	Min.	Max.	UOM
ADVANCED				
Superheat setpoint	11	LowSH: threshold	180 (324)	K (°F)
Discharge superheat setpoint	35	-40 (-72)	180 (324)	K (°F)
Discharge temperature setpoint	105	-60 (-76)	200 (392)	°C (°F)

Tab. 5.g



**Note:**

- this control function is only available CAREL valve drivers.
- no set point needs to be configured by the user.

### 5.5 Superheat regulation with 2 temperature probes

The functional diagram is shown below. This type of control must be used with care, due to the lower precision of the temperature probe compared to the probe that measures the saturated evaporation pressure.

Parameter/Description	Def.
CONFIGURATION	
Main control	multiplexed showcase/cold room
...	
superheat regulation with 2 temperature probes	

Tab. 5.h

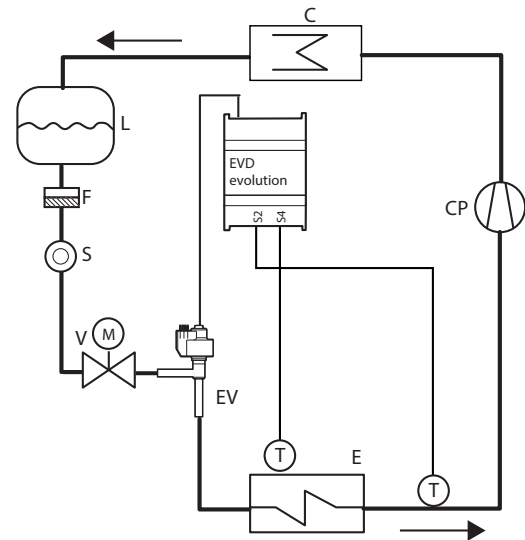

Fig. 5.e

Key:

CP	Compressor	V	Solenoid valve
C	Condenser	S	Liquid gauge
L	Liquid receiver	EV	Electronic valve
F	Dewatering filter	E	Evaporator
T	Temperature probe		

Parameter/Description	Def.	Min.	Max.	UOM
ADVANCED				
Superheat setpoint	11	LowSH: threshold	180 (324)	K (°F)
PID: proportional gain	15	0	800	-
PID: integral time	150	0	1000	s
PID: derivative time	5	0	800	s

Tab. 5.i

## 5.6 Advanced regulation

### EPR back pressure

This type of control can be used in many applications in which a constant pressure is required in the refrigerant circuit. For example, a refrigeration system may include different showcases that operate at different temperatures (showcases for frozen foods, meat or dairy). The different temperatures of the circuits are achieved using pressure regulators installed in series with each circuit. The special EPR function (Evaporator Pressure Regulator) is used to set a pressure set point and the PID control parameters required to achieve this.

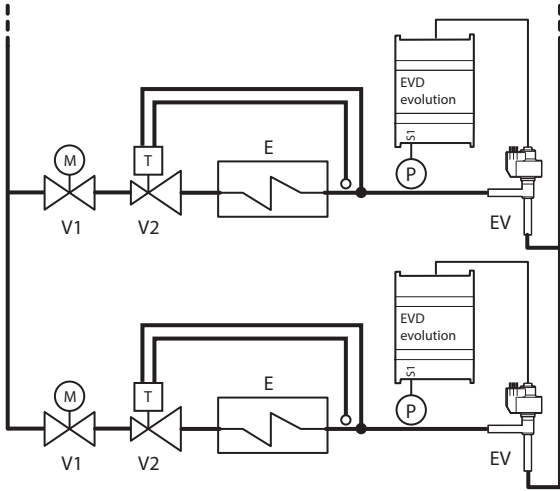

Fig. 5.f

Key:

V1	Solenoid valve	E	Evaporator
V2	Thermostatic expansion valve	EV	Electronic valve

For the wiring, see paragraph "General connection diagram".

This involves PID control without any protectors (LowSH, LOP, MOP, High Tcond, see the chapter on Protectors), and without auxiliary control. Control is performed on the pressure probe value read by input S1, compared to the set point: "EPR pressure set point". Control is direct, as the pressure increases, the valve opens and vice-versa.

Parameter/description	Def.	Min.	Max.	UOM
<b>CONTROL</b>				
EPR pressure set point	3.5	-20 (-290)	200 (2900)	barg (psig)
PID proport. gain	15	0	800	-
PID integration time	150	0	1000	s
PID derivative time	5	0	800	s

Tab. 5.j

### Hot gas bypass by pressure

This control function can be used to control cooling capacity. If there is no request from circuit B, the compressor suction pressure decreases and the bypass valve opens to let a greater quantity of hot gas flow and decrease the capacity of the circuit.

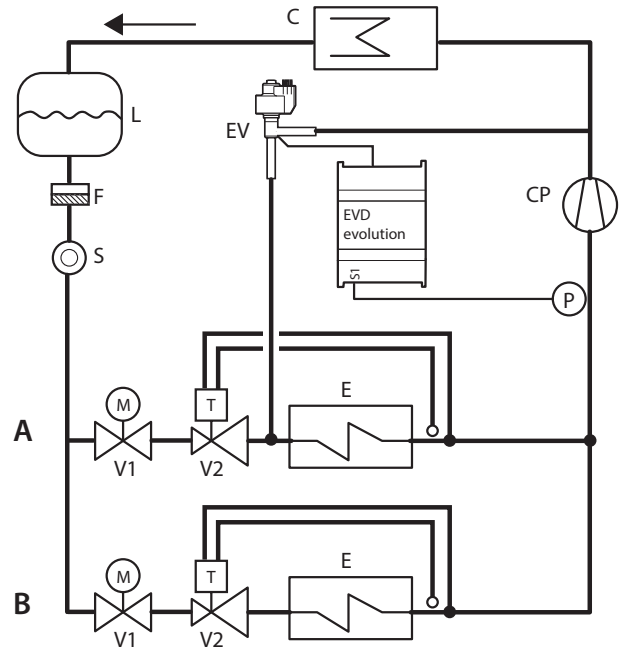

Fig. 5.g

Key:

CP	Compressor	V1	Solenoid valve
C	Condenser	V2	Thermostatic expansion valve
L	Liquid receiver	EV	Electronic valve
F	Dewatering filter	E	Evaporator
S	Liquid indicator		

For the wiring, see paragraph "General connection diagram".

This involves PID control without any protectors (LowSH, LOP, MOP, High Tcond, see the chapter on Protectors), and without auxiliary control. Control is performed on the hot gas bypass pressure probe value read by input S1, compared to the set point: "Hot gas bypass pressure set point". Control is reverse, as the pressure increases, the valve closes and vice-versa.

Parameter/description	Def.	Min.	Max.	UOM
<b>CONTROL</b>				
Hot gas bypass pressure set point	3	-20 (290)	200 (2900)	barg (psig)
PID proport. gain	15	0	800	-
PID integration time	150	0	1000	s
PID derivative time	5	0	800	s

Tab. 5.k

**Hot gas bypass by temperature**

This control function can be used to control cooling capacity. On a refrigerated cabinet, if the ambient temperature probe measures an increase in the temperature, the cooling capacity must also increase, and so the valve must close.

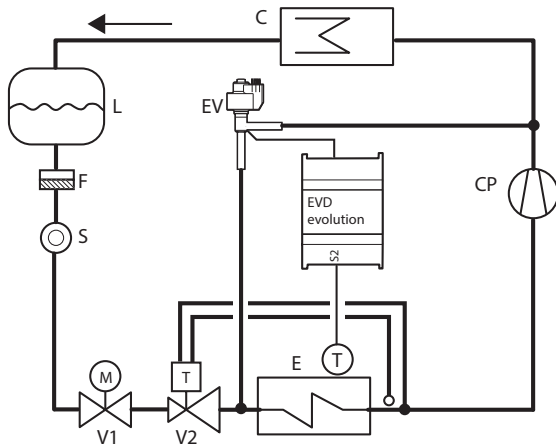

Fig. 5.h

**Key:**

CP	Compressor	V1	Solenoid valve
C	Condenser	V2	Thermostatic expansion valve
L	Liquid receiver	EV	Electronic valve
F	Dewatering filter	E	Evaporator
S	Liquid indicator		

For the wiring, see paragraph "General connection diagram".

This involves PID control without any protectors (LowSH, LOP, MOP, High Tcond, see the chapter on Protectors), and without auxiliary control. Control is performed on the hot gas bypass temperature probe value read by input S2, compared to the set point: "Hot gas bypass temperature set point".

Control is reverse, as the temperature increases, the valve closes.

Parameter/description	Def.	Min.	Max.	UOM
<b>CONTROL</b>				
Hot gas bypass temp. set point	10	-60 (-76)	200 (392)	°C (°F)
PID: proportional gain	15	0	800	-
PID integration time	150	0	1000	s
PID derivative time	5	0	800	s

Tab. 5.l

Another application that exploits this control function uses the connection of two EXV valves together to simulate the effect of a three-way valve, called "reheating". To control humidity, valve EV\_1 is opened to let the refrigerant flow into exchanger S. At the same time, the air that flows through evaporator E is cooled and the excess humidity removed, yet the temperature is below the set room temperature. It then flows through exchanger S, which heats it back to the set point (reheating).

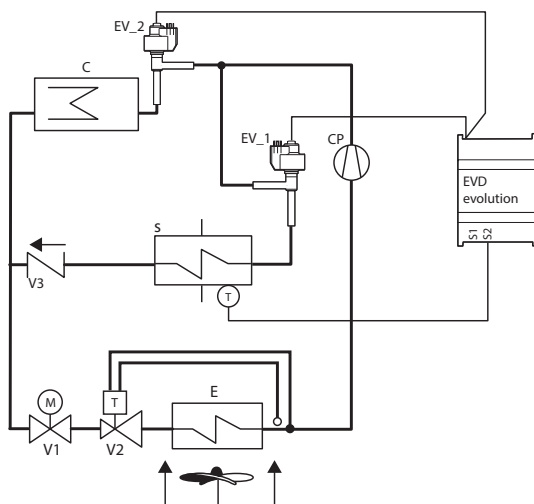

Fig. 5.i

**Key:**

"EVD evolution" +0300005EN - rel. 4.2 - 24.01.2024

CP	Compressor	EV_1	Electronic valves connected in complementary mode
		EV_2	
C	Condenser	T	Temperature probe
V1	Solenoid valve	E	Evaporator
V3	Non-return valve	V2	Thermostatic expansion valve
S	Heat exchanger (reheating)		

**Transcritical CO<sub>2</sub> gas cooler**

This solution for the use of CO<sub>2</sub> in refrigerating systems with a transcritical cycle involves using a gas cooler, that is a refrigerant/air heat exchanger resistant to high pressures, in place of the condenser. In transcritical operating conditions, for a certain gas cooler outlet temperature, there is pressure that optimises the efficiency of the system:

$$Set = A \cdot T + B$$

Set = pressure set point in a gas cooler with transcritical CO<sub>2</sub>

T = gas cooler outlet temperature

Default value: A = 3.3, B = -22.7.

In the simplified diagram shown below, the simplest solution in conceptual terms is shown. The complications in the systems arise due to the high pressure and the need to optimise efficiency.

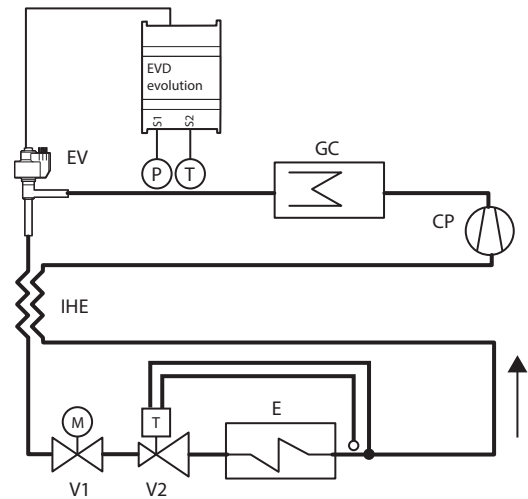

Fig. 5.j

**Key:**

CP	Compressor	V2	Thermostatic expansion valve
GC	Gas cooler	EV	Electronic valve
E	Evaporator	IHE	Inside heat exchanger
V1	Solenoid valve		

For the wiring, see paragraph "General connection diagram".

This involves PID control without any protectors (LowSH, LOP, MOP, High Tcond, see the chapter on Protectors), and without auxiliary control. Control is performed on the gas cooler pressure probe value read by input S1, with a set point depending on the gas cooler temperature read by input S2; consequently there is not a set point parameter, but rather a formula:

"CO<sub>2</sub> gas cooler pressure set point" = Coefficient A \* Tgas cooler (S2) + Coefficient B. The set point calculated will be a variable that is visible in display mode. Control is direct, as the pressure increases, the valve opens.

Parameter/description	Def.	Min.	Max.	UOM
<b>ADVANCED</b>				
CO <sub>2</sub> regul. 'A' coefficient	3.3	-100	800	-
CO <sub>2</sub> regul. 'B' coefficient	-22.7	-100	800	-
<b>CONTROL</b>				
PID proport. gain	15	0	800	-
PID integration time	150	0	1000	s
PID derivative time	5	0	800	s

Tab. 5.m

**Analogue positioner (4 to 20 mA)**

The valve will be positioned linearly depending on the value of the “4 to 20 mA input for analogue valve positioning” read by input S1. There is no PID control nor any protection (LowSH, LOP, MOP, High Tcond, see the chapter on Protectors), and no auxiliary control.

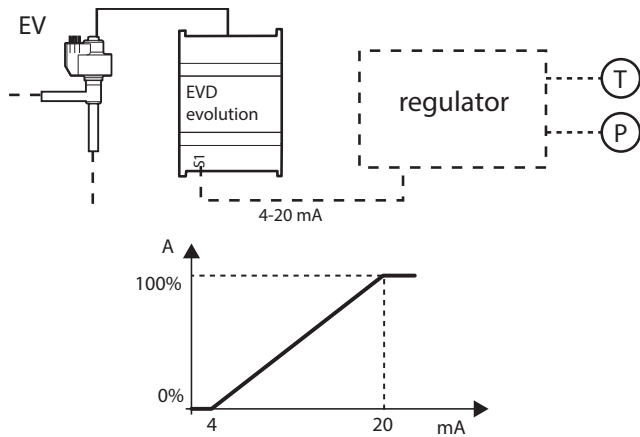

Fig. 5.k

**Key:**  
EV Electronic valve                      A Valve opening

For the wiring, see paragraph “General connection diagram”. Forced closing will only occur when digital input DI1 opens, thus switching between control status and standby. The pre-positioning and repositioning procedures are not performed. Manual positioning can be enabled when control is active or in standby.

**Analogue positioner (0 to 10 Vdc)**

The valve will be positioned linearly depending on the value of the “0 to 10 V input for analogue valve positioning” read by input S1. There is no PID control nor any protection (LowSH, LOP, MOP, High Tcond), and no auxiliary control, with corresponding forced closing of the valve and changeover to standby status.

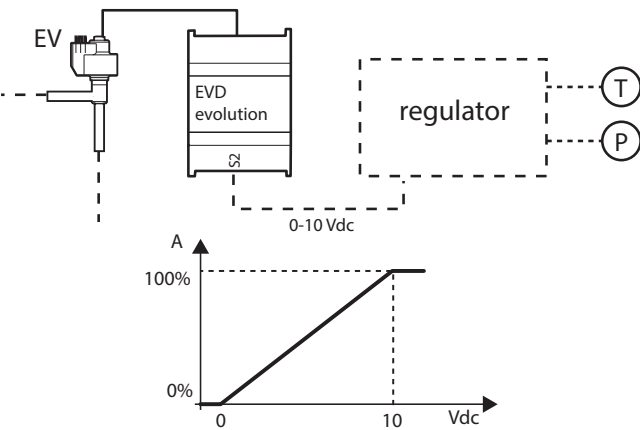

Fig. 5.l

**Key:**  
EV Electronic valve                      A Valve opening

For the wiring, see paragraph “General connection diagram”.

**⚠ Important:** the pre-positioning and repositioning procedures are not performed. Manual positioning can be enabled when control is active or in standby.

**I/O expander for pCO**

The EVD Evolution driver is connected to the pCO programmable controller via LAN, transferring the probe readings quickly and without filtering. The driver operates as a simple actuator, and receives the information needed to manage the valves from the pCO.

Parameter/Description	Def.
<b>CONFIGURATION</b>	
Main control	multiplexed showcase/cold room
...	
I/O expander for pCO	

Tab. 5.n

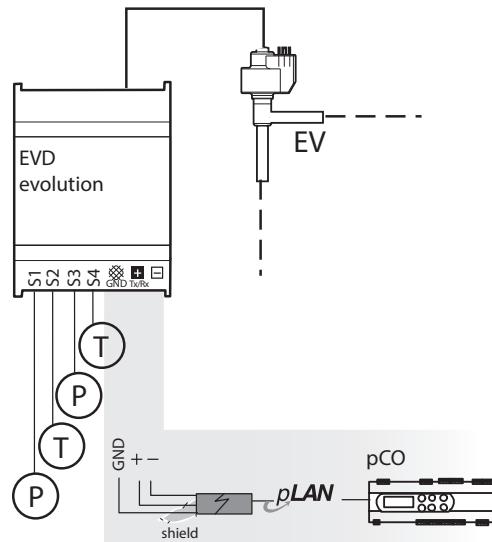

Fig. 5.m

**Key:**  
T Temperature probe                      P Pressure probe  
EV Electronic valve

**5.7 Programmable control**

The following types of programmable control are available:

- Programmable superheat control (SH);
- Programmable special control;
- Programmable positioner.

Parameter/description	Def	Min	Max	U.M.
<b>CONFIGURATION</b>				
Main control	Multiplexed cabinet / cold room	-	-	-
...				
22= Programmable SH control				
23 = Programmable special control				
24 = Programmable positioner				
...				
<b>SPECIAL</b>				
Programmable control configuration	0	0	32767	-
Programmable control input	0	0	32767	-
Programmable SH control options	0	0	32767	-
Programmable control set point	0	-800 (-11603)	800 (11603)	

Tab. 5.o

The table shows the programmable control functions and the related parameter settings.

Function	Parameter to be set
Direct/reverse setting	Programmable control configuration
Type of physical value controlled	Programmable control configuration
Input processing to determine measurement	Programmable control configuration
Correction to each individual input for integration in measurement calculation	Programmable control input
Association between physical inputs and logical outputs	Programmable control input outputs

**Note:** the control error is the result of the difference between the set point and the measurement:

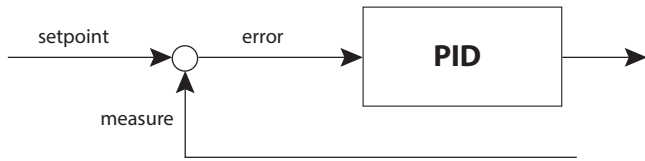

Direct operation: error = measurement - set point  
 Reverse operation: error = set point - measurement

**Programmable control configuration**

Each digit in the "Programmable control configuration" parameter has a special meaning, depending on its position:

POSITION	DESCRIPTION	NOTE
Tens of thousands (DM)	Control: direct/reverse	Select type of control action: direct/reverse
Thousands (M)	Auxiliary control	Selection any auxiliary control or protector used for superheat control
Hundreds	Do not select	-
Tens	Controlled value	Select the type of controlled physical value (temperature, pressure...)
Units	Measurement function	Select the function for calculating the value controlled by the PID (measurement)

Tab. 5.p

**Direct/reverse control – Tens of thousands**

Value	Description
0	PID in direct control
1	PID in reverse control
2,...,9	-

**AUX control - Thousands**

Value	Description
0	None
1	HITCond protection
2	Modulating thermostat
3	HiTcond protection in reverse
4,...,9	-

**Hundreds – DO NOT SELECT**

**Controlled value - Tens**

Value	Description
0	Temperature (°C/°F), absolute
1	Temperature (K/°F), relative
2	Pressure (bar/psi), absolute
3	Pressure (barg/psig), relative
4	Current (mA) for control
5	Voltage (V) for control
6	Voltage (V) for positioner
7	Current (mA) for positioner
8,9	-

**Measurement function - Units**

Value	Description
0	f1(S1)+ f2(S2)+ f3(S3)+ f4(S4)
1,...,9	-

**Programmable control input**

The function assigned to each input is defined by parameter - "Programmable control input". The parameter has 16 bits and is divided into 4 digits, as described in "Programmable control configuration", corresponding to the 4 probes, S1, S2, S3, S4.

POSITION	DESCRIPTION
Thousands	Function of probe S1
Hundreds	Function of probe S2
Tens	Function of probe S3
Units	Function of probe S4
Value	Input function
0	0
1	+ Sn
2	- Sn
3	+ Tdew (Sn)(*)
4	- Tdew (Sn)
5	+ Tbub (Sn)(**)
6	- Tbub (Sn)
7,8,9	-

(\*): Tdew() = function for calculating the saturated evaporation temperature according to the type of gas.

(\*\*): Tbubble = function for calculating the condensing temperature.

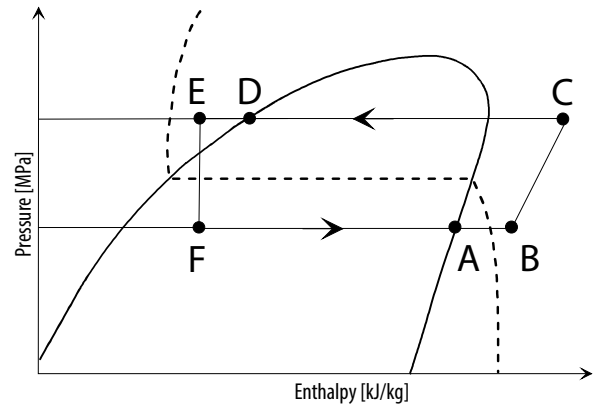

Fig. 5.n

Key:

TA	Saturated evaporation temperature = Tdew
TB	Superheated gas temperature = suction temperature
TB - TA	Superheat
TD	Condensing temperature (TBUBBLE)
TE	Subcooled gas temperature
TD - TE	Subcooling

**Options/ programmable control set point**

**Note:**

- if Control = Programmable special control, the setting of the "Programmable control options" parameter has no affect;
- if Control = "Programmable positioner", the settings of the "Programmable control options" and "Programmable control set point" parameters have no affect.

The physical value measured is assigned to the individual probes S1 to S4 by the "Programmable control options" parameter. The parameter has 16 bits and is divided into 4 digits, as described in "Programmable control configuration", corresponding to the 4 probes, S1, S2, S3, S4. The control set point si sets to the "Programmable control set point" parameter.

POSITION	DESCRIPTION
Thousands	Function of probe S1
Hundreds	Function of probe S2
Tens	Function of probe S3
Units	Function of probe S4

Value	Input function
0	None
1	Suction temperature
2	Evaporation pressure
3	Evaporation temperature
4	Condensing pressure
5	Condensing temperature
6	Temperature (modulating thermostat)
7,8,9	-

**Note:**

if several inputs are associated with the same logical meaning, EVD Evolution considers the one associated with the input that has the highest index.

**Examples**

EXAMPLE 1

- Main control = 22 → Programmable SH control;
- Programmable control configuration = 01010; Direct PID temperature control; high condensing temperature protection (HITCond) enabled;
- Programmable control input = 0041 → Measurement = S4-Tdew(S3)
- Programmable control options = 4021:
  - S1= condensing pressure,
  - S3=evaporation pressure,
  - S4=suction temperature.
- Programmable control set point = 8.0 (°C).

Examining each digit, it can be seen that this involves superheat control performed by measuring the suction temperature with probe S4 and determining the evaporation temperature by converting the pressure read by probe S3 to temperature. Moreover, high condensing temperature protection (HITCond) is selected on probe S1. PID control is direct, with a set point of 8°C.

EXAMPLE 2

- Main control = 23 → Programmable special control;
- Programmable control configuration=00040, direct control current;
- Programmable control input = 1000 → Measurement =S1
- Programmable control options = XXXX: no affect
- Programmable control set point = 16.0 (mA)

This involves PID control of refrigerant liquid level with flooded evaporator, using the current at input S1 as the measurement and a set point of 16 mA, with direct PID control of the valve.

EXAMPLE 3

- Main control = 23 → Programmable special control;
- Programmable control configuration = 10050 → reverse PID voltage control;
- Programmable control input = 0100 → Measurement =S2
- Programmable control options = XXXX: no affect
- Programmable control set point = 7.0 (V)

This involves control of refrigerant liquid level with flooded evaporator, using the voltage value at input S2 as the measurement and a set point of 7.0 V, with reverse PID control of the valve.

EXAMPLE 4

- Main control = 24 → Programmable positioner;
- Programmable control configuration = 00070 → current (mA) for positioner;
- Programmable control input = 00010 → Measurement =S3;
- Programmable control options = XXXX: no affect;
- Programmable control set point = XXXX: no affect.

This involves a 4 to 20 mA analogue positioner (without PID): the valve will be positioned linearly, depending on the “4 to 20 mA input value for analogue valve positioning”, read by input S3.

### 5.8 Control with refrigerant level sensor

In the flooded shell and tube evaporator and in the flooded condenser, the refrigerant vaporises outside of the tubes, which are immersed in the liquid refrigerant. The hot fluid flowing through the tubes is cooled, transferring heat to the refrigerant surrounding the tubes, so that this boils, with gas exiting from the top, which is taken in by the compressor.

Parameter/description	Def	Min	Max	UOM
<b>CONFIGURATION</b>				
Probe S1	Ratiometric:-1...9.3 barg	-	-	-
...				
24 = CAREL liquid level				
...				
Main control	Multiplexed cabinet/ cold room	-	-	-
...				
25 = Evaporator liquid level control with CAREL sensor				
26 = Condenser liquid level control with CAREL sensor				
<b>CONTROL</b>				
Liquid level set point	50	0	100	%

The action is reverse: if the liquid level measured by the float level sensor is higher (lower) than the set point, the EEV valve closes (opens).

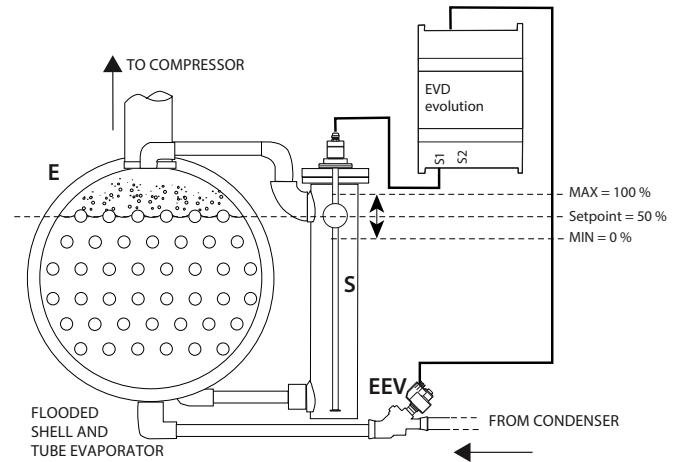

Fig. 5.0

Key:

S	Float level sensor
EEV	Electronic valve
E	Flooded evaporator

With the condenser, the action is direct: if the liquid level measured by the float level sensor is lower (higher) than the set point, the EEV valve closes (opens).

For the wiring, see paragraph “General connection diagram”.

### 5.9 Auxiliary control

Auxiliary control can be activated at the same time as main control, and uses the probes connected to inputs S3 and/or S4.

Parameter/description	Def.
<b>CONFIGURATION</b>	
Auxiliary control:	Disabled
1=Disabled; 2=High condensing temperature protection on S3 probe; 3=Modulating thermostat on S4 probe; 4=Backup probes on S3 & S4; 5, 6, 7 = Reserved; 8 = Subcooling measurement; 9 = Reverse high condensing temperature protection on S3	

Tab. 5.q

For the high condensing temperature protection (only available with superheat control), an additional pressure probe is connected to S3 that measures the condensing pressure.

For the modulating thermostat function (only available with superheat control), an additional temperature probe is connected to S4 that measures the temperature on used to perform temperature control (see the corresponding paragraph).

The last option (available if “main control”= 1 to 18) requires the installation of both probes S3 & S4, the first pressure and the second temperature.

**Note:** if only one backup probe is fitted, under the manufacture parameters, the probe thresholds and alarm management can be set separately.

### HITCond protection (high condensing temperature)

The functional diagram is shown below.

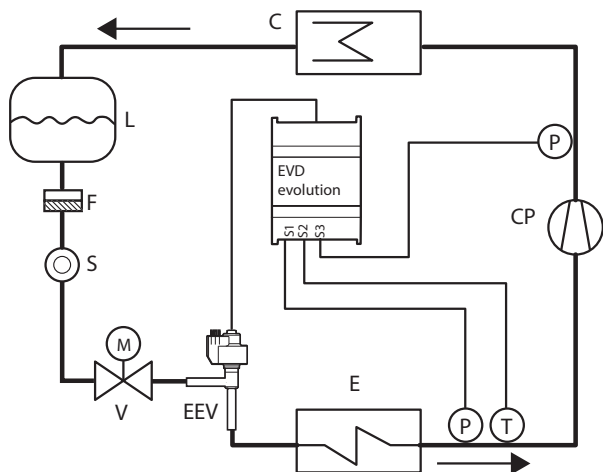

Fig. 5.p

**Key:**

CP	Compressor	EEV	Electronic expansion valve
C	Condenser	V	Solenoid valve
L	Liquid receiver	E	Evaporator
F	Dewatering filter	P	Pressure probe (transducer)
S	Liquid indicator	T	Temperature probe

For the wiring, see paragraph "General connection diagram".

As already mentioned, the HITCond protection can only be enabled if the controller measures the condensing pressure/temperature, and responds moderately by closing the valve in the event where the condensing temperature reaches excessive values, to prevent the compressor from shutting down due to high pressure. The condensing pressure probe must be connected to input S3.

### Modulating thermostat

This function is used, by connecting a temperature probe to input S4, to modulate the opening of the electronic valve so as to limit the lowering of the temperature read and consequently reach the control set point. This is useful in applications such as the multiplexed cabinets to avoid the typical swings in air temperature due to the ON/OFF control (thermostatic) of the solenoid valve. A temperature probe must be connected to input S4, located in a similar position to the one used for the traditional temperature control of the cabinet. In practice, the closer the controlled temperature gets to the set point, the more the control function decreases the cooling capacity of the evaporator by closing the expansion valve. By correctly setting the related parameters (see below), a very stable cabinet temperature can be achieved around the set point, without ever closing the solenoid valve. The function is defined by three parameters: set point, differential and offset.

Parameter/description	Def.	Min.	Max.	UOM
<b>ADVANCED</b>				
Modul. thermost setpoint	0	-60 (-76)	200 (392)	°C (°F)
Modul. thermost differential	0.1	0.1 (0.2)	100 (180)	°C (°F)
Modul. thermost SHset offset (0= function disabled)	0	0 (0)	100 (180)	K (°R)

Tab. 5.r

The first two should have values similar to those set on the controller for the cabinet or utility whose temperature is being modulated. The offset, on the other hand, defines the intensity in closing the valve as the temperature decreases: the greater the offset, the more the valve will be modulated. The function is only active in a temperature band between the set point and the set point plus the differential.

**⚠ Important:** the "Modulating thermostat" function should not be used on stand-alone refrigeration units, but only in centralised systems. In fact, in the former case closing the valve would cause a lowering of the pressure and consequently shut down the compressor.

Examples of operation:

1. offset too low (or function disabled)

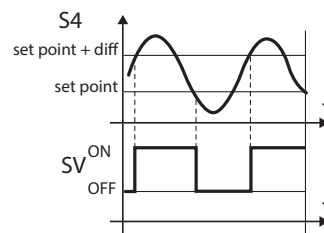

2. offset too high

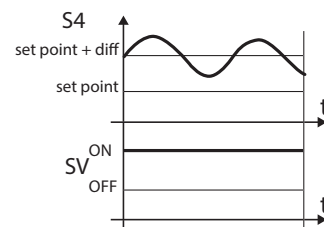

3. offset correct

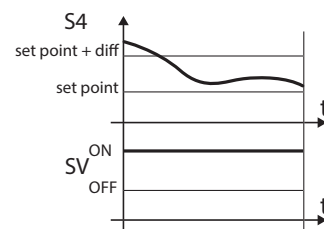

Fig. 5.q

**Key:**

diff= differential  
SV= solenoid valve (showcase temperature control)  
S4= temperature

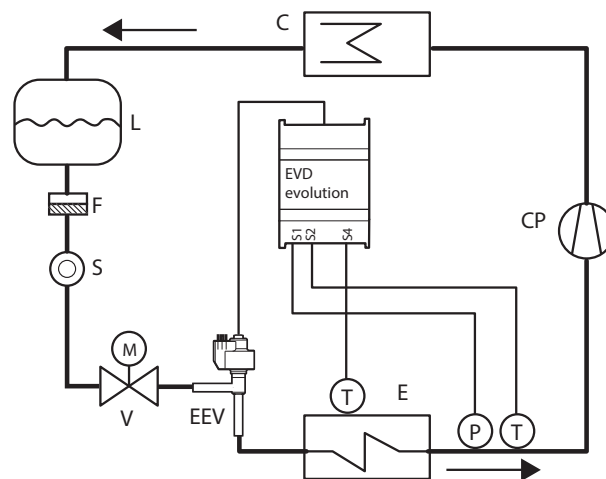

Fig. 5.r

**Key:**

CP	Compressor	EEV	Electronic expansion valve
C	Condenser	V	Solenoid valve
L	Liquid receiver	E	Evaporator
F	Dewatering filter	P	Pressure probe (transducer)
S	Liquid indicator	T	Temperature probe

For the wiring, see paragraph "General connection diagram".

**Backup probes on S3 & S4**

**⚠ Important:** this type of control is compatible with the “main control” parameter setting between 1 and 18.

In this case, pressure probe S3 and temperature probe S4 will be used to replace probes S1 and S2 respectively in the event of faults on one or both, so as to guarantee a high level of reliability of the controlled unit.

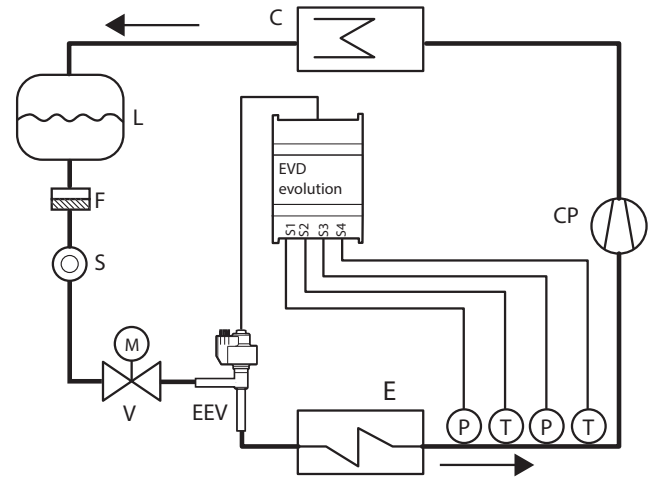

Fig. 5.s

Key:

CP	Compressor	EEV	Electronic expansion valve
C	Condenser	V	Solenoid valve
L	Liquid receiver	E	Evaporator
F	Dewatering filter	P	Pressure probe (transducer)
S	Liquid indicator	T	Temperature probe

For the wiring, see paragraph “General connection diagram”.

**Subcooling measurement**

This function measures subcooling using a pressure probe and a temperature probe connected to inputs S3 and S4 respectively. The reading can be sent to a controller connected in the serial network (e.g. pCO).

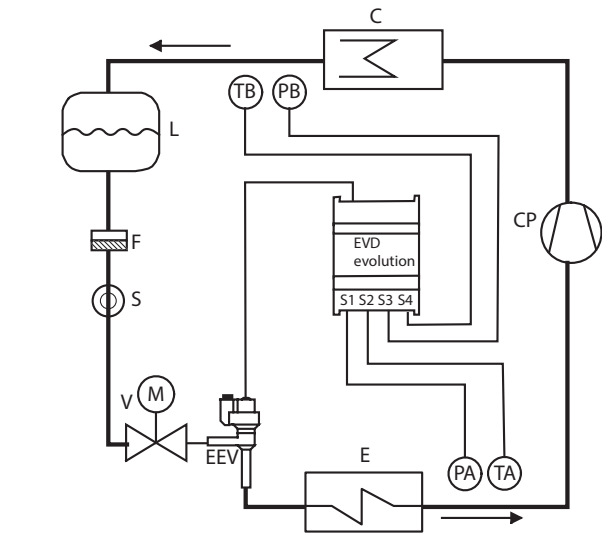

Fig. 5.t

Key:

CP	Compressor	EEV	Electronic expansion valve
C	Condenser	V	Solenoid valve
L	Liquid receiver	E	Evaporator
F	Filter-drier	PA, PB	Pressure probes
S	Liquid gauge	TA, TB	Temperature probes

For the wiring, see paragraph “General connection diagram”.

The subcooling measurement uses the difference between the condensing temperature taken from the relative pressure reading and the temperature of the liquid refrigerant exiting the condenser. This measurement indicates the refrigerant charge in the circuit.

A value near 0 K indicates possible insufficient refrigerant, which may cause a decline in circuit cooling efficiency, a reduction in mass flow through the expansion valve and swings in superheat control. In addition, it may indicate a refrigerant leak in circuits where the nominal subcooling value is known.

A subcooling value that is too high, for example above 20 K, when not required by the application may indicate excessive refrigerant charge in the circuit, and can cause unusually high condensing pressure values with a consequent decline in circuit cooling efficiency and possible compressor shutdown due to the high pressure switch tripping.

**Reverse high condensing temperature protection (HiTcond) on S3**

The aim of reverse HiTcond protection is to limit the condensing pressure in the refrigerant circuit by opening the valve rather than closing it. This function is recommended, rather than the HiTcond protection function described previously, in refrigerant circuits without a liquid receiver and where the condenser is smaller than the evaporator (e.g. air-to-water heat pumps). In this case, in fact, closing the valve would obstruct the flow of refrigerant to the condenser that, lacking sufficient volume for the refrigerant to accumulate, would cause an increase in condensing pressure. This function is especially useful for condensers in CO<sub>2</sub> cascade systems. See the chapter on Protectors.

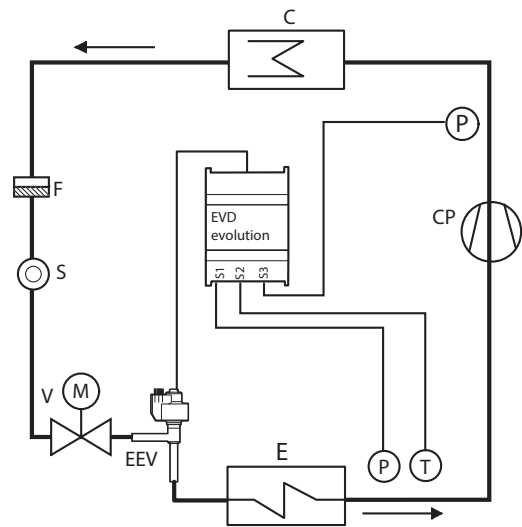

Fig. 5.u

Key:

CP	Compressor	EEV	Electronic expansion valve
C	Condenser	V	Solenoid valve
F	Filter-drier	E	Evaporator
S	Liquid gauge	P	Pressure probe (transducer)
T	Temperature probe		

For the wiring, see paragraph “General connection diagram”.

## 6. FUNCTIONS

### 6.1 Power supply mode

EVD evolution can be powered at 24 Vac or 24 Vdc. In the event of direct current power supply, after completing the commissioning procedure, to start control set "Power supply mode" parameter=1.

Parameter/Description	Def.	Min.	Max.	UOM
<b>ADVANCED</b>				
Power supply mode	0	0	1	-
0=24 Vac				
1= 24 Vdc				

Tab. 6.a

**Important:** with direct current power supply, in the event of power failures emergency closing of the valve is not performed, even if the EVD0000UC0 module is connected.

### 6.2 Battery charge delay

Battery charge delay to allow battery charging. In the presence of a battery to close the valve, to avoid missing emergency closing in case of repeated and close blackouts, a regulation start delay has been introduced, configurable by the user depending on the backup system used (ultracap or lead battery). This delay, if set to a value > 0, occurs every time the driver is turned on to allow the battery to recharge.

Parameter/description	Def.
<b>ADVANCED</b>	
Battery charge delay	0 min

Tab. 6.b

### 6.3 Network connection

**Important:** to set the pLAN address, follow the guidelines in chap.4.

To connect an RS485/Modbus® controller to the network, as well as the network address parameter (see paragraph 4.2), using the "Network settings" parameter.

Parameter	Description	Def.
<b>SPECIAL</b>		
Set configuration	parity Bit stop Baud rate	
0	none parity 2 bit stop 4800 bps	
1	none parity 2 bit stop 9600 bps	
2	none parity 2 bit stop 19200 bps	x
4	none parity 1 bit stop 4800 bps	
5	none parity 1 bit stop 9600 bps	
6	none parity 1 bit stop 19200 bps	
16	even parity 2 bit stop 4800 bps	
17	even parity 2 bit stop 9600 bps	
18	even parity 2 bit stop 19200 bps	
20	even parity 1 bit stop 4800 bps	
21	even parity 1 bit stop 9600 bps	
22	even parity 1 bit stop 19200 bps	
24	odd parity 2 bit stop 4800 bps	
25	odd parity 2 bit stop 9600 bps	
26	odd parity 2 bit stop 19200 bps	
28	odd parity 1 bit stop 4800 bps	
29	odd parity 1 bit stop 9600 bps	
30	odd parity 1 bit stop 19200 bps	

Tab. 6.c

**Note:** To use the Carel protocol you must use the default settings:

- byte size: 8 bits;
- stop bits: 2;
- parity: none.

### 6.4 Inputs and outputs

#### Analogue inputs

The parameters in question concern the choice of the type pressure/liquid probe S1 and S3 and the choice of the temperature probe S2 and S4, as well as the possibility to calibrate the pressure and temperature signals. As regards the choice of pressure/liquid probe S1 and S3, see the chapter on "Commissioning".

#### Inputs S2, S4

The options are standard NTC probes, high temperature NTC, combined temperature and pressure probes and 0 to 10 Vdc input. For S4 the 0 to 10 Vdc input is not available. When choosing the type of probe, the minimum and maximum alarm values are automatically set. See the chapter on "Alarms". The auxiliary probe S4 is used in various applications (e.g.: superheat control with BLDC compressor, I/O expansion for pCO, subcooling measurement) or can be used as a backup probe for the main probe S2.

Type	CAREL code	Range
CAREL NTC (10KΩ at 25°C)	NTC0**HP00	-50T105°C
	NTC0**WF00	
	NTC0**HF00	
CAREL NTC-HT HT (50KΩ at 25°C)	NTC0**HT00	-30T150°C
NTC built-in	SPKP**T0	-40T120°C
NTC low temperature	NTC*LT*	-80T60°C

Tab. 6.d

**Important:** in case of NTC built-in probe, select also the parameter relevant to the corresponding ratiometric pressure probe.

Parameter/description	Def.
<b>CONFIGURATION</b>	
Probe S2:	CAREL NTC
1= CAREL NTC; 2= CAREL NTC-HT high T; 3= NTC built-in SPKP**T0; 4= 0-10 V external signal; 5= NTC - LT CAREL low temp.	
Probe S4:	CAREL NTC
1= CAREL NTC; 2= CAREL NTC-HT high T; 3= NTC built-in SPKP**T0; 4= -- ; 5= NTC - LT CAREL low temperature	

Tab. 6.e

#### Input S3

The auxiliary probe S3 is associated with the high condensing temperature protection or can be used as a backup probe for the main probe S1. If the probe being used is not included in the list, select any 0 to 5 V ratiometric or electronic 4 to 20 mA probe and then manually modify the minimum and maximum measurement in the manufacturer parameters corresponding to the probes.

**Important:**

- probes S1 and S3 must be the same type, therefore if S1 is a ratiometric probe (pressure probe or CAREL liquid level probe), S3 must also be ratiometric;
- probes S3 and S4 are shown as NOT USED if the "auxiliary control" parameter is set as "disabled". If "auxiliary control" has any other setting, the manufacturer setting for the probe used will be shown, which can be selected according to the type.
- Probe S1 = CAREL liquid level must be set with "Main control"="Evaporator liquid level control with CAREL sensor" or "Condenser liquid level control with CAREL sensor". Probe S3 = CAREL liquid level is set in the case of liquid level control with programmable control.

Auxiliary control	Variable displayed
High condensing temperature protection	S3
Modulating thermostat	S4
Backup probes	S3,S4
Subcooling measurement	S3, S4
Reverse high condensing temp. protection on S3	S3

Tab. 6.f

Parameter/description	Def.
<b>Configuration</b>	
Probe S3:	Ratiom.:
0 = custom	-1 to 9.3 barg
Ratiometric (OUT=0 to 5 V)	Electronic (OUT=4 to 20 mA)
1= -1 to 4.2 barg	8= -0.5 to 7 barg
2= 0.4 to 9.3 barg	9= 0 to 10 barg
3= -1 to 9.3 barg	10= 0 to 18,2 barg
4= 0 to 17.3 barg	11= 0 to 25 barg
5= 0.85 to 34.2 barg	12= 0 to 30 barg
6= 0 to 34.5 barg	13= 0 to 44.8 barg
7= 0 to 45 barg	14= remote, -0.5 to 7 barg
	15= remote, 0 to 10 barg
	16= remote, 0 to 18,2 barg
	17= remote, 0 to 25 barg
	18= remote, 0 to 30 barg
	19= remote, 0 to 44.8 barg
	20= 4-20 mA external signal (cannot be selected)
	Ratiom.:
	-1 to 9.3 barg
21= -1 to 12,8 barg	
22= 0 to 20,7 barg	
23= 1.86 to 43,0 barg	
24 =CAREL liquid level	
25 = 0...60,0 barg	
26 = 0...90,0 barg	
27 = external signal 0...5V	

Tab. 6.g

(\*) for programmable positioner. See chapter "Control".

### Calibrating pressure probes S1, S3 and temperature probes S2 and S4 (offset and gain parameters)

In case it is necessary to make a calibration:

- of the pressure probe, S1 and/or S3 it is possible to use the offset parameter, which represents a constant that is added to the signal across the entire range of measurement, and can be expressed in barg/psig. If the 4 to 20 mA signal coming from an external controller on input S1 needs to be calibrated, both the offset and the gain parameters can be used, the latter which modifies the gradient of the line in the field from 4 to 20 mA.
- of the temperature probe, S2 and/or S4 it is possible to use the offset parameter, which represents a constant that is added to the signal across the entire range of measurement, and can be expressed in °C/°F. If the 0 to 10 Vdc signal coming from an external controller on input S2 needs to be calibrated, both the offset and the gain parameters can be used, the latter which modifies the gradient of the line in the field from 0 to 10 Vdc.

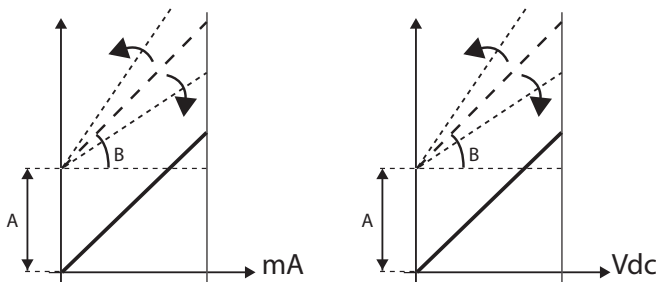

Fig. 6.a

Key:  
A= offset  
B= gain

Parameter/description	Def.	Min.	Max.	UOM
<b>PROBES</b>				
S1 calibration offset	0	-60 (-870), -60	60 (870), 60	barg (psig), mA
S1 calibration gain on 4-20 mA	1	-20	20	-
S2 calibration offset	0	-20 (-290), -20	20 (290), 20	°C (°F), volt
S2 calibration gain, 0 to 10 V	1	-20	20	-
S3 calibration offset	0	-60 (-870)	60 (870)	barg (psig)
S4 calibration offset	0	-20 (-36)	20 (36)	°C (°F)

Tab. 6.h

### Digital inputs

The functions of digital inputs 1 and 2 can be set by parameter, as shown in the table below:

Parameter/description	Def.	Min.	Max.	UOM
<b>CONFIGURATION</b>				
DI1 configuration	5/6	1	7	-
1= Disabled				
2= Valve regulation optimization after defrost				
3= Discharged battery alarm management				
4= Valve forced open (at 100%)				
5= Regulation start/stop				
6= Regulation backup				
7= Regulation security				
<b>CONTROL</b>				
Start delay after defrost	10	0	60	min

Tab. 6.i

**Valve regulation optimization after defrost:** the selected digital input tells the driver the current defrost status.

Defrost active = contact closed.

Access Manufacturer programming mode to set the start delay after defrost.

**Discharged battery alarm management:** if the selected digital input is connected to the battery charge module for EVD evolution, EVBAT00400, the controller signals discharged or faulty batteries, so as to generate an alarm message and warn the service technicians that maintenance is required. See the connection diagram in chapter 2.

**Valve forced open:** when the digital input closes, the valve opens completely (100%), unconditionally. When the contact opens again the valve closes and moves to the position defined by the parameter "valve opening at start-up" for the pre-position time. Control can then start.

#### Regulation start/stop:

digital input closed: control active;

digital input open: driver in standby (see the paragraph "Control status");



**Important:** this setting excludes activation/deactivation of control via the network. See the following functions.

- Regulation backup: if there is a network connection and communication fails, the driver checks the status of the digital input to determine whether control is active or in standby;
- Regulation security: if there is a network connection, before control is activated the driver must receive the control activation signal and the selected digital input must be closed. If the digital input is open, the driver always remains in standby.

#### Priority of digital inputs

In certain cases the setting of digital inputs 1 and 2 may be the same or alternatively may be incompatible (e.g.: digital input 1 = regulation backup, digital input 2 = regulation security). The problem thus arises to determine which function the driver needs to perform.

Consequently, each type of function is assigned a priority, primary (PRIM) or secondary (SEC), as shown in the table:

DI1/DI2 configuration	Type of function
1=Disabled	SEC
2=Valve regulation optimization after defrost	SEC
3=Discharged battery alarm management	SEC
4=Valve forced open (at 100%)	SEC
5=Regulation start/stop	PRIM
6=Regulation backup	PRIM
7=Regulation security	PRIM

There are four possible cases of digital input configurations with primary or secondary functions.

Function set		Function performed by digital input	
DI1	DI2	PRIM	SEC
PRIM	PRIM	DI1	-
PRIM	SEC	DI1	DI2
SEC	PRIM	DI2	DI1
SEC	SEC	Regulation backup	DI1 (supervisor variable)

Note that:

- if digital inputs 1 and 2 are set to perform a PRIM function, only the function set for input 1 is performed;
- if the digital inputs 1 and 2 are set to perform a SEC function, only the SEC function set for input 1 is performed; the driver will be set to "Regulation backup" with the value of the digital input determined by the "Regulation backup from supervisor" variable.

**Relay output**

The relay output can be configured as:

- alarm relay output. See the chapter on Alarms;
- solenoid valve control;
- electronic expansion valve status signal relay. The relay contact is only open if the valve is closed (opening=0%). As soon as control starts (opening >0%, with hysteresis), the relay contact is closed
- relay control signal: the relay is managed by a digital variable accessible via serial (direct relay control signal).

Parameter/description	Def.
<b>CONFIGURATION</b>	
Relay configuration:	Alarm relay
1= Disabled; 2= alarm relay (opened in case of alarm); 3= Solenoid valve relay (open in standby); 4= valve + alarm relay (open in standby and control alarms); 5= Reversed alarm relay (closed in case of alarm); 6= Valve status relay (open if valve is closed); 7 = Direct control; 8 = Failed closing alarm relay (open with alarm); 9 = reverse failed closing alarm relay (closed with alarm)	

Tab. 6.j

**6.5 Control status**

The electronic valve driver has 6 different types of control status, each of which may correspond to a specific phase in the operation of the refrigeration unit and a certain status of the driver-valve system.

The status may be as follows:

- **forced closing:** initialisation of the valve position when switching the instrument on;
- **standby:** no temperature control, unit OFF;
- **wait:** opening of the valve before starting control, also called pre-positioning, when powering the unit and in the delay after defrosting;
- **control:** effective control of the electronic valve, unit ON;
- **positioning:** step-change in the valve position, corresponding to the start of control when the cooling capacity of the controlled unit varies (only for LAN EVD connected to a pCO);
- **stop:** end of control with the closing of the valve, corresponds to the end of temperature control of the refrigeration unit, unit OFF;
- **valve motor error recognition:** see paragraph 9.5
- **tuning in progress:** see paragraph 5.3.

**Forced closing**

Forced closing is performed after the driver is powered-up and corresponds to a number of closing steps equal to the parameter "Closing steps", based on the type valve selected. This is used to realign the valve to the physical position corresponding to completely closed. The driver and the valve are then ready for control and both aligned at 0 (zero). On power-up, first a forced closing is performed, and then the standby phase starts.

Parametro/description	Def.	Min.	Max.	UOM
<b>VALVE</b>				
EEV closing steps	500	0	9999	step

Tab. 6.k

The valve is closed in the event of power failures with 24 Vac power supply when the EVD0000UC0 module is connected. In this case, the parameter "Forced valve closing not completed", visible only on the supervisor, is forced to 1. If when restarting forced closing of the valve was not successful:

1. the Main programmable controller checks the value of the parameter and if this is equal to 1, decides the best strategy to implement based on the application;
2. the driver on restart positions the valve as explained in the paragraph "Pre-positioning/start control The parameter is reset to 0 (zero) by the Main controller (e.g. pCO), once the parameter has been set to 1 the driver returns it to 0 (zero) only if forced emergency closing is completed successfully.



**Note:** delayed control start to recharge battery. If a battery is used to close the valve in the event of a power failure, to prevent emergency closing from failing due to repeated blackouts, a delay has been introduced that can be set by the user depending on the backup system used (Ultracap or lead-acid battery). This delay, if configured (default = 0), is applied every time the driver is powered on, to allow the battery to recharge.

Parameter/description	Def.	Min.	Max.	UoM
<b>SPECIAL</b>				
	0	0	255	min.

Tab. 6.l

**Standby**

Standby corresponds to a situation of rest in which no signals are received to control the electronic valve. This normally occurs:

- when the refrigeration unit stops operating, either when switched off manually (e.g. from the button, supervisor) or when reaching the control set point;
- during defrosts, except for those performed by reversing of the cycle (or hot gas bypass).

In general, it can be said that the electronic valve driver is in standby when the compressor stops or the solenoid valve closes. The valve is closed or open according to the setting of "Valve open in standby". The percentage of opening is set using "Valve position in standby". In this phase, manual positioning can be activated.

Parameter/description	Def.	Min.	Max.	UOM
<b>CONTROL</b>				
Valve open in standby	0	0	1	-
0=disabled=valve closed; 1=enabled = valve open according to parameter "Valve position in standby"				
Valve position in standby	0	0	100	%
0 = 25 % (*) 1...100% = % opening (**)				

Tab. 6.m

These two parameters determine the position of the valve in standby based on the minimum and maximum number of valve steps.

Parameter/description	Def.	Min.	Max.	UOM
<b>VALVE</b>				
Minimum EEV steps	50	0	9999	step
Maximum EEV steps	480	0	9999	step

Tab. 6.n

(\*) The formula used is:

$$\text{Apertura / Opening} = \frac{\text{Min\_step\_EEV} + (\text{Max\_step\_EEV} - \text{Min\_step\_EEV}) / 100 * 25}{}$$

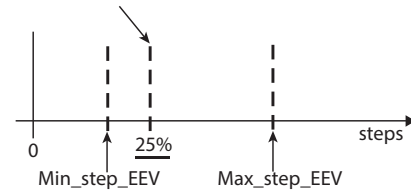

Fig. 6.b

(\*\*) In this case, the formula used is:

$$\text{Apertura / Opening} = P * (\text{Max\_step\_EEV} / 100)$$

P = Posizione valvola in stand-by / Position valve in stand-by

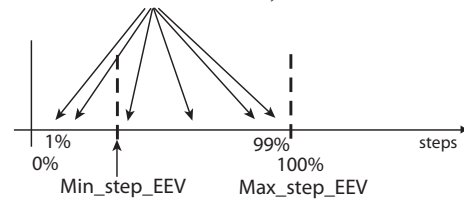

Fig. 6.c



**Note:** if "Valve open in standby"=1, the positions of the valve when setting "Valve position in standby"=0 and 25 do not coincide. Refer to the above formulae.

**Pre-positioning/start control**

If during standby a control request is received, before starting control the valve is moved to a precise initial position.

The pre-position time is the time the valve is held in a steady position based on the parameter "Valve opening at start-up".

Parameter/description	Def.	Min.	Max.	UOM
<b>CONTROL</b>				
Pre-positioning time	6	0	18000	s
Valve opening at start-up (evaporator/valve capacity ratio)	50	0	100	%

Tab. 6.o

The valve opening parameter should be set based on the ratio between the rated cooling capacity of the evaporator and the valve (e.g. rated evaporator cooling capacity: 3kW, rated valve cooling capacity: 10kW, valve opening = 3/10 = 33%).

**If the capacity request is 100%:**

Opening (%)= (Valve opening at start-up);

**If the capacity request is less than 100% (capacity control):**

Opening (%)= (Valve opening at start-up) · (Current unit cooling capacity), where the current unit cooling capacity is sent to the driver via LAN by the pCO controller. If the driver is stand-alone, this is always equal to 100%.

**Note:**

- this procedure is used to anticipate the movement and bring the valve significantly closer to the operating position in the phases immediately after the unit starts;
- if there are problems with liquid return after the refrigeration unit starts or in units that frequently switch on-off, the valve opening at start-up must be decreased. If there are problems with low pressure after the refrigeration unit starts, the valve opening must be increased.

**Wait**

When the calculated position has been reached, regardless of the time taken (this varies according to the type of valve and the objective position), there is a constant 5 second delay before the actual control phase starts. This is to create a reasonable interval between standby, in which the variables have no meaning, as there is no flow of refrigerant, and the effective control phase.

**Control**

The control request can be received by the closing of digital input 1 or via the network (LAN). The solenoid or the compressor are activated when the valve, following the pre-positioning procedure, has reached the calculated position. The following figure represents the sequence of events for starting control of the refrigeration unit.

**Control delay after defrost**

Some types of refrigerating cabinets have problems controlling the electronic valve in the operating phase after defrost. In this period (10 to 20 min after defrosting), the superheat measurement may be altered by the high temperature of the copper pipes and the air, causing excessive opening of the electronic valve for extended periods, in which there is return of liquid to the compressors that is not detected by the probes connected to the driver. In addition, the accumulation of refrigerant in the evaporator in this phase is difficult to dissipate in a short time, even after the probes have started to correctly measure the presence of liquid (superheat value low or null).

The driver can receive information on the defrost phase in progress, via digital input 2. The "Start-up delay after defrost" parameter is used to set a delay when control resumes so as to overcome this problem. During this delay, the valve will remain in the pre-positioning point, while all the normal probe alarms procedures, etc. managed.

Parameter/description	Def.	Min.	Max.	UOM
<b>CONTROL</b>				
Start-up delay after defrost	10	0	60	min

Tab. 6.p

**Important:** if the superheat temperature should fall below the set point, control resumes even if the delay has not yet elapsed.

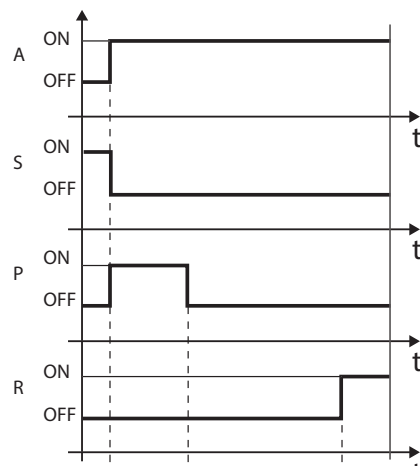

Fig. 6.d

**Key:**

A	Control request	W	Wait
S	Standby	T1	Pre-positioning time
P	Pre-positioning	T2	Start-up delay after defrost
R	Control	t	Time

**Positioning (change cooling capacity)**

This control status is only valid for the driver connected to the pCO via LAN. If there is a change in unit cooling capacity of at least 10%, sent from the pCO via the pLAN, the valve is positioned proportionally. In practice, this involves repositioning starting from the current position in proportion to how much the cooling capacity of the unit has increased or decreased in percentage terms. When the calculated position has been reached, regardless of the time taken (this varies according to the type of valve and the position), there is a constant 5 second delay before the actual control phase starts.

**Note:** if information is not available on the variation in unit cooling capacity, this will always be considered as operating at 100% and therefore the procedure will never be used. In this case, the PID control must be more reactive (see the chapter on Control) so as to react promptly to variations in load that are not communicated to the driver.

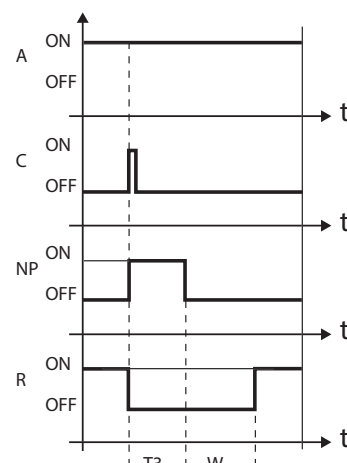

Fig. 6.e

**Key:**

A	Control request	T3	Repositioning time
C	Change capacity	W	Wait
NP	Repositioning	t	Time
R	Control		

**Stop/end control**

The stop procedure involves closing the valve from the current position until reaching 0 steps, plus a further number of steps so as to guarantee complete closing. Following the stop phase, the valve returns to standby.

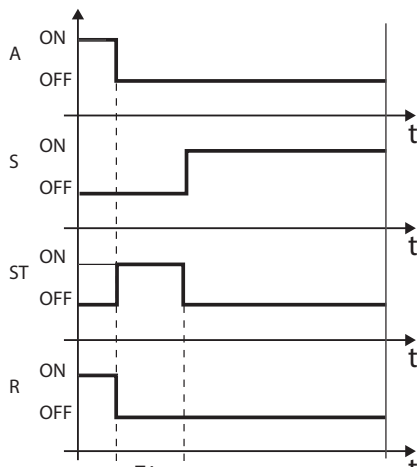

Fig. 6.f

Key:

A	Control request	R	Control
S	Standby	T4	Stop position time
ST	Stop	t	Time

### 6.6 Advanced control status

As well as normal control status, the driver can have 3 special types of status related to specific functions:

- **manual positioning:** this is used to interrupt control so as to move the valve, setting the desired position;
- **recover physical valve position:** recover physical valve steps when fully opened or closed.

#### Manual positioning

Manual positioning can be activated at any time during the standby or control phase. Manual positioning, once enabled, is used to freely set the position of the valve using the corresponding parameter.

Control is placed on hold, all the system and control alarms are enabled, however neither control nor the protectors can be activated. Manual positioning thus has priority over any status/protection of the driver

When the driver is connected to the network (for example to a pCO controller), in presence of an communication-error (LAN error), manual positioning can be inhibited temporarily by the parameter and the driver recognizes the start/stop regulation, depending on the configuration of the digital inputs.

Parameter/description	Def.	Min.	Max.	UOM
<b>CONTROL</b>				
Enable manual valve position	0	0	1	-
Manual valve position	0	0	9999	step
Stop manual positioning on network error	0	0	1	-

0 = Normal operation; 1 = Stop

Tab. 6.q

**Note:**

- the manual positioning status is NOT saved when restarting after a power failure.
- in for any reason the valve needs to be kept stationary after a power failure, proceed as follows:
  - remove the valve stator;
  - in Manufacturer programming mode, under the configuration parameters, set the PID proportional gain= 0. The valve will remain stopped at the initial opening position, set by corresponding parameter.

### Recover physical valve position

Parameter/description	Def.	Min.	Max.	UOM
<b>VALVE</b>				
EEV opening synchroniz.	1	0	1	-
EEV closing synchroniz.	1	0	1	-

Tab. 6.r

This procedure is necessary as the stepper motor intrinsically tends to lose steps during movement. Given that the control phase may last continuously for several hours, it is probable that from a certain time on the estimated position sent by the valve driver does not correspond exactly to the physical position of the movable element. This means that when the driver reaches the estimated fully closed or fully open position, the valve may physically not be in that position. The "Synchronisation" procedure allows the driver to perform a certain number of steps in the suitable direction to realign the valve when fully opened or closed.

**Note:**

- realignment is in intrinsic part of the forced closing procedure and is activated whenever the driver is stopped/started and in the standby phase;
- the possibility to enable or disable the synchronisation procedure depends on the mechanics of the valve. When the setting the "valve" parameter, the two synchronisation parameters are automatically defined. The default values should not be changed.

### 6.7 Quick probe alarm disabling

From firmware version 9.0-9.1 it is possible to disable the quick probe alarm management.

By default this is disabled.

Parameter/Description	Def.	Min.	Max.	U.M.
<b>PROBES</b>				
Quick probe alarm disable	0	0	1	-

**Caution:** to be able to see the parameters in paragraph 6.7, a Display P/N EVDIS00\*\*0 is required, version 4.9 or higher, or a VPM with firmware version 9.0-9.1.

## 7. PROTECTORS

These are additional functions that are activated in specific situations that are potentially dangerous for the unit being controlled. They feature an integral action, that is, the action increases gradually when moving away from the activation threshold. They may add to or overlap (disabling) normal PID superheat control. By separating the management of these functions from PID control, the parameters can be set separately, allowing, for example, normal control that is less reactive yet much faster in responding when exceeding the activation limits of one of the protectors.

### 7.1 Protectors

The protectors are 5:

- LowSH, low superheat;
- LOP, low evaporation temperature;
- MOP, high evaporation temperature;
- High Tcond, high condensing temperature;
- Reverse HiTcond.

**Note:** the HiTcond protectors require an additional probe (S3) to those normally used, either installed on the driver, or connected via tLAN, pLAN, RS485/ Modbus® to a controller.

The protectors have the following main features:

- activation threshold: depending on the operating conditions of the controlled unit, this is set in Service programming mode;
- integration time, which determines the intensity (if set to 0, the protector is disabled): set automatically based on the type of main control;
- alarm, with activation threshold (the same as the protector) and timeout (if set to 0 disables the alarm signal).

**Note:** The alarm signal is independent from the effectiveness of the protector, and only signals that the corresponding threshold has been exceeded. If a protector is disabled (null integration time), the relative alarm signal is also disabled.

Each protector is affected by the proportional gain parameter (K) for the PID superheat control. The higher the value of K, the more intense the reaction of the protector will be.

#### Characteristics of the protectors

Protection	Reaction	Reset
LowSH	Intense closing	Immediate
LOP	Intense opening	Immediate
MOP	Moderate closing	Controlled
High Tcond	Moderate closing	Controlled
Reverse HiTcond	Moderate opening	Controlled

Tab. 7.a

**Reaction:** summary description of the type of action in controlling the valve.

**Reset:** summary description of the type of reset following the activation of the protector. Reset is controlled to avoid swings around the activation threshold or immediate reactivation of the protector.

#### LowSH (low superheat)

The protector is activated so as to prevent the return of liquid to the compressor due to excessively low superheat valves from.

Parameter/description	Def.	Min.	Max.	UOM
<b>CONTROL</b>				
LowSH protection threshold	5	-40 (-72)	set point superheat	K (°F)
LowSH protection integration time	15	0	800	s
<b>ALARM CONFIGURATION</b>				
Low superheat alarm timeout (LowSH) (0= alarm DISABLED)	300	0	18000	s

Tab. 7.b

When the superheat value falls below the threshold, the system enters low superheat status, and the intensity with which the valve is closed is increased: the more the superheat falls below the threshold, the more intensely the valve will close. The LowSH threshold, must be less than or equal to the superheat set point. The low superheat integration time indicates the intensity of the action: the lower the value, the more intense the action.

*The integration time is set automatically based on the type of main control.*

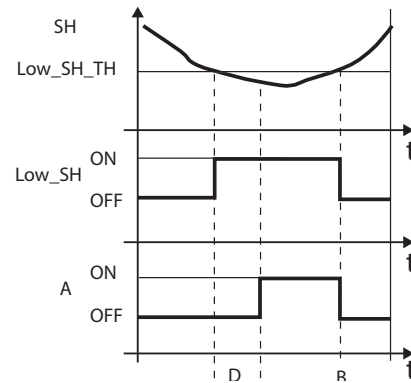

Fig. 7.a

Key:

SH	Superheat	A	Alarm
Low_SH_TH	Low_SH protection threshold	D	Alarm timeout
Low_SH	Low_SH protection	t	Time
B	Automatic alarm reset		

#### LOP (low evaporation pressure)

LOP= Low Operating Pressure

The LOP protection threshold is applied as a saturated evaporation temperature value so that it can be easily compared against the technical specifications supplied by the manufacturers of the compressors. The protector is activated so as to prevent too low evaporation temperatures from stopping the compressor due to the activation of the low pressure switch. The protector is very useful in units with compressors on board (especially multi-stage), where when starting or increasing capacity the evaporation temperature tends to drop suddenly.

When the evaporation temperature falls below the low evaporation temperature threshold, the system enters LOP status and the intensity with which the valve is opened is increased. The further the temperature falls below the threshold, the more intensely the valve will open. The integration time indicates the intensity of the action: the lower the value, the more intense the action.

Parameter/description	Def.	Min.	Max.	UOM
<b>CONTROL</b>				
LOP protection threshold	-50	-60 (-76)	Protection MOP: threshold	°C (°F)
LOP protection integration time	0	0	800	s
<b>ALARM CONFIGURATION</b>				
Low evaporation temperature alarm timeout (LOP) (0= alarm DISABLED)	300	0	18000	s

Tab. 7.c

The integration time is set automatically based on the type of main control.

**Note:**

- the LOP threshold must be lower than the rated evaporation temperature of the unit, otherwise it would be activated unnecessarily, and greater than the calibration of the low pressure switch, otherwise it would be useless. As an initial approximation it can be set to a value exactly half-way between the two limits indicated;
- the protector has no purpose in multiplexed systems (showcases) where the evaporation is kept constant and the status of the individual electronic valve does not affect the pressure value;

- the LOP alarm can be used as an alarm to highlight refrigerant leaks by the circuit. A refrigerant leak in fact causes an abnormal lowering of the evaporation temperature that is proportional, in terms of speed and extent, to the amount of refrigerant dispersed;
- if the measured superheat is lower than the set point the LOP protection does not work.

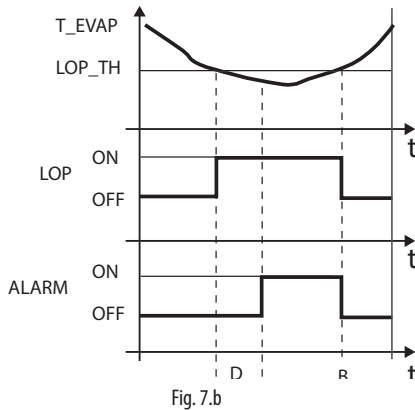

Fig. 7.b

**Key:**

T_EVAP	Evaporation temperature	D	Alarm timeout
LOP_TH	Low evaporation temperature protection threshold	ALARM	Alarm
LOP	LOP protection	t	Time
B	Automatic alarm reset		

**MOP (high evaporation pressure)**

MOP= Maximum Operating Pressure.

The MOP protection threshold is applied as a saturated evaporation temperature value so that it can be easily compared against the technical specifications supplied by the manufacturers of the compressors. The protector is activated so as to prevent too high evaporation temperatures from causing an excessive workload for the compressor, with consequent overheating of the motor and possible activation of the thermal protector. The protector is very useful in self-contained units if starting with a high refrigerant charge or when there are sudden variations in the load. The protector is also useful in multiplexed systems (showcases), as allows all the utilities to be enabled at the same time without causing problems of high pressure for the compressors. To reduce the evaporation temperature, the output of the refrigeration unit needs to be decreased. This can be done by controlled closing of the electronic valve, implying superheat is no longer controlled, and an increase in the superheat temperature. The protector will thus have a moderate reaction that tends to limit the increase in the evaporation temperature, keeping it below the activation threshold while trying to stop the superheat from increasing as much as possible. Normal operating conditions will not resume based on the activation of the protector, but rather on the reduction in the refrigerant charge that caused the increase in temperature. The system will therefore remain in the best operating conditions (a little below the threshold) until the load conditions change.

Parameter/description	Def.	Min.	Max.	UOM
<b>CONTROL</b>				
MOP protection threshold	50	Protection LOP: threshold	200 (392)	°C (°F)
MOP protection integration time	20	0	800	s
<b>ALARM CONFIGURATION</b>				
High evaporation temperature alarm timeout (MOP) (0= alarm DISABLED)	600	0	18000	s

Tab. 7.d

The integration time is set automatically based on the type of main control.

When the evaporation temperature rises above the MOP threshold, the system enters MOP status, superheat regulation is interrupted to allow the pressure to be controlled, and the valve closes slowly, trying to limit the evaporation temperature.

As the action is integral, it depends directly on the difference between the evaporation temperature and the activation threshold. The more the evaporation temperature increases with reference to the MOP threshold, the more intensely the valve will close. The integration time indicates the intensity of the action: the lower the value, the more intense the action.

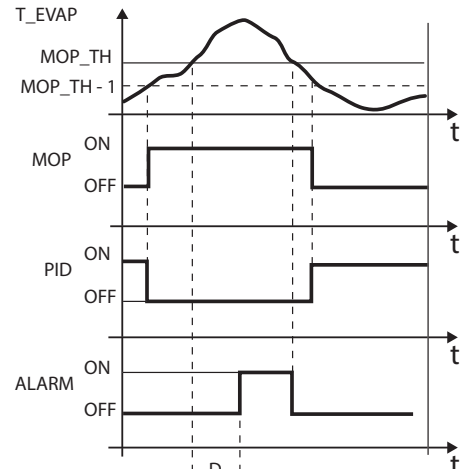

Fig. 7.c

**Key:**

T_EVAP	Evaporation temperature	MOP_TH	MOP threshold
PID	PID superheat control	ALARM	Alarm
MOP	MOP protection	t	Time
D	Alarm timeout		



**Important:** the MOP threshold must be greater than the rated evaporation temperature of the unit, otherwise it would be activated unnecessarily. The MOP threshold is often supplied by the manufacturer of the compressor. It is usually between 10 °C and 15 °C.

If the closing of the valve also causes an excessive increase in the suction temperature (S2) above the set threshold – only set via supervisor (PlantVisor, pCO, VPM), not on the display - the valve will be stopped to prevent overheating the compressor windings, awaiting a reduction in the refrigerant charge. If the MOP protection function is disabled by setting the integral time to zero, the maximum suction temperature control is also deactivated.

Parameter/description	Def.	Min.	Max.	UOM
<b>CONTROL</b>				
MOP protection: suction temperature threshold	30	-60 (-72)	200 (392)	°C (°F)

Tab. 7.e

At the end of the MOP protection function, superheat regulation restarts in a controlled manner to prevent the evaporation temperature from exceeding the threshold again.

If the suction temperature is greater than or equal to the set temperature protection threshold, the MOP protection does not work.

**High Tcond (high condensing temperature)**

To activate the high condensing temperature protector (High Tcond), a pressure probe must be connected to input S3.

The protector is activated so as to prevent too high evaporation temperatures from stopping the compressor due to the activation of the high pressure switch.

Parameter/description	Def.	Min.	Max.	UOM
<b>ADVANCED</b>				
High Tcond threshold	80	-60 (-76)	200 (392)	°C (°F)
High Tcond integration time	20	0	800	s
<b>ALARM CONFIGURATION</b>				
High condensing temperature alarm timeout (High Tcond) (0= alarm DISABLED)	600	0	18000	s

Tab. 7.f

The integration time is set automatically based on the type of main control.

**Note:**

- the protector is very useful in units with compressors on board if the air-cooled condenser is undersized or dirty/malfunctioning in the more critical operating conditions (high outside temperature);
- the protector has no purpose in multiplexed systems (showcases), where the condensing pressure is maintained constant and the status of the individual electronic valves does not affect the pressure value.

To reduce the condensing temperature, the output of the refrigeration unit needs to be decreased. This can be done by controlled closing of the electronic valve, implying superheat is no longer controlled, and an increase in the superheat temperature. The protector will thus have a moderate reaction that tends to limit the increase in the condensing temperature, keeping it below the activation threshold while trying to stop the superheat from increasing as much as possible. Normal operating conditions will not resume based on the activation of the protector, but rather on the reduction in the outside temperature. The system will therefore remain in the best operating conditions (a little below the threshold) until the environmental conditions change.

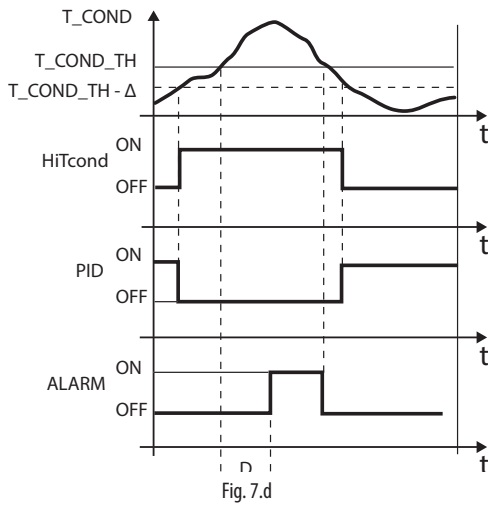

**Key:**

T_COND	Condensing temperature	T_COND_TH	High Tcond threshold
High Tcond	High Tcond protection status	ALARM	Alarm
PID	PID superheat control	t	Time
D	Alarm timeout		

**Note:**

- the High Tcond threshold must be greater than the rated condensing temperature of the unit and lower than the calibration of the high pressure switch;
- the closing of the valve will be limited if this causes an excessive decrease in the evaporation temperature.

**Reverse HiTcond (for CO<sub>2</sub> cascade systems)**

As mentioned earlier, reverse high condensing temperature protection (HiTcond) on S3, opens the valve to limit refrigerant circuit condensing pressure by filling part of the evaporator. The graph of how the function works is similar to the one shown for HiTcond protection.

**Important:** opening the valve will probably also cause activation of the low superheat protection LowSH, which tends to limit the opening of the valve. The ratio between the integral times of these two concurrent yet opposing protectors determines how effective one is compared to the other.

This function is especially useful for condensers in CO<sub>2</sub> cascade systems, where condensation in the low temperature circuit (also called "secondary", B) takes place when evaporating the refrigerant in the medium temperature circuit ("primary", A).

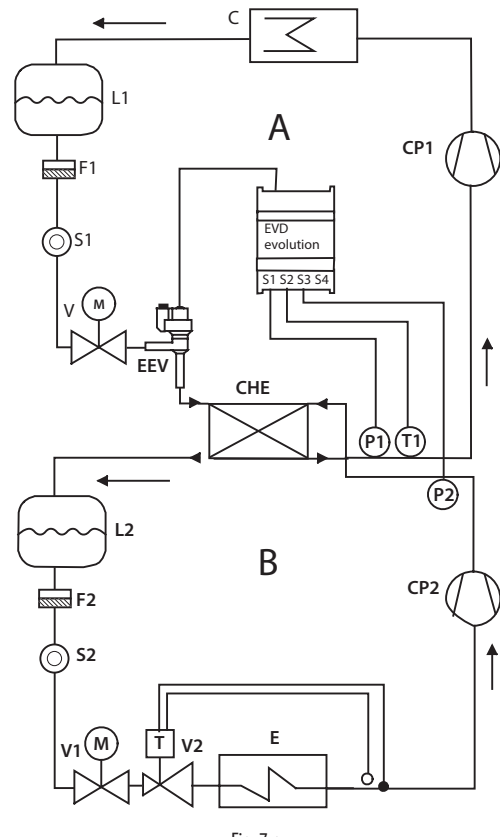

**Key:**

CP1/2	Compressor 1/2	EEV	Electronic expansion valve
CHE	Cascade heat exchanger	C	Condenser
L1/2	Liquid receiver 1/2	V	Solenoid valve
F1/2	Filter-drier 1/2	E	Evaporator
S1/2	Liquid gauge 1/2	P1/2	Pressure probe (transducer)
T1	Temperature probe	V2	Thermostatic expansion valve

For the wiring, see paragraph "General connection diagram"

**Note:** for this type of application, the auxiliary refrigerant must be set as CO<sub>2</sub> (R744).

Parameter / Description	Def.
Refrigerant	Alls refrigerants, not R744
Main regulation	Subcooling regulation 1...10
Auxiliary refrigerant	R744

The driver controls refrigerant superheat in the primary circuit (A), and at the same time measures the refrigerant condensing pressure in the secondary circuit (B). When the condensing temperature exceeds the HiTCond protection threshold, normal superheat control is overridden by forced opening of the valve, at a rate that is inversely proportional to the HiTCond protection integral time. Opening the EEV lowers the superheat in the primary circuit, which increases the heat exchange coefficient and consequently reduces the condensing pressure in the secondary circuit.

The reverse HiTcond threshold for CO<sub>2</sub> cascade applications should be set in relation to the expected evaporation temperature in the primary circuit. The threshold must be set to a value that is at least 3-5°C higher than the minimum evaporation temperature in the primary circuit. Lower values make achieving the set pressure limit incompatible with heat exchange efficiency. In addition, swings in operation may occur due the attempt to limit low superheat in the primary circuit and the pressure in the secondary circuit at the same time.

## 8. PARAMETERS TABLE

user*	Parameter/description	Def.	Min.	Max.	UOM	Type**	CAREL SVP	Modbus®	Notes
CONFIGURATION									
A	Network address	pLAN: 30 others: 198	1	207	-	I	11	138	
A	Refrigerant: 0= user defined; 1= R22    2= R134a    3= R404A    4= R407C    5= R410A 6= R507A    7= R290    8= R600    9= R600a    10= R717 11= R744    12= R728    13= R1270    14= R417A    15= R422D 16= R413A    17= R422A    18= R423A    19= R407A    20= R427A 21= R245FA    22= R407F    23= R32    24= HTR01    25= HTR02 26= R23    27= R1234yf    28= R1234ze    29= R455A    30= R170 31= R442A    32= R447A    33= R448A    34= R449A    35= R450A 36= R452A    37= R508B    38= R452B    39= R513A    40= R454B 41= R458A    42= R407H    43= R454A    44= R454C    45= R470A 46= R515B    47= R466A	R404A	-	-	-	I	13	140	
A	Valve: 0= user defined    13= Sporlan SEH 175    26= CAREL ejector E2J23AT1N0 1= CAREL E <sup>V</sup> 14= Danfoss ETS 12.5-25B    27= CAREL ejector E3J26AT2N0 2= Alco EX4    15= Danfoss ETS 50B    28= CAREL ejector E3J33AU2N0 3= Alco EX5    16= Danfoss ETS 100B    29= CAREL ejector E3J39AV3N0 4= Alco EX6    17= Danfoss ETS 250    30= CAREL ejector E6J50AV3N0 5= Alco EX7    18= Danfoss ETS 400    31= Danfoss CCMT 16 6= Alco EX8 330Hz    19= Two E <sup>V</sup> CAREL    32= Danfoss CCMT 24 recommend CAREL connected together 7= Alco EX8 500Hz    20= Sporlan SER(I)G,J,K    33= Danfoss CCMT 30 specific Alco 8= Sporlan SEI 0.5-11    21= Danfoss CCM    34= Danfoss CCMT 42 10-20-30 9= Sporlan SER 1.5-20    22= Danfoss CCM 40    35= Danfoss Colibri 10= Sporlan SEI 30    23= Danfoss CCMT 2-4-8 11= Sporlan SEI 50    24= Disabled 12= Sporlan SEH 100    25= CAREL ejector E2J17AS1N0	CAREL E <sup>V</sup>	-	-	-	I	14	141	
A	Probe S1: 0= user defined <b>Ratiometric (OUT=0...5 V)</b> 1= -1...-4,2 barg    8= -0,5...-7 barg 2= -0,4...-9,3 barg    9= 0...10 barg 3= -1...-9,3 barg    10= 0...18,2 barg 4= 0...17,3 barg    11= 0...25 barg 5= 0,85...34,2 barg    12= 0...30 barg 6= 0...34,5 barg    13= 0...44,8 barg 7= 0...45 barg    14= remoto, -0,5...-7 barg 21= -1...12,8 barg    15= remoto, 0...10 barg 22= 0...20,7 barg    16= remoto, 0...18,2 barg 23= 1,86...43,0 barg    17= remoto, 0...25 barg 24= Livello liquido CAREL    18= remoto, 0...30 barg 25= 0...60,0 barg    19= remoto, 0...44,8 barg 26= 0...90,0 barg    20= external signal 4...20 mA 27= external signal 0...5 V	Ratiometric: -1 to 9,3 barg	-	-	-	I	16	143	
A	Main control: 0= user defined    14= transcritical CO <sub>2</sub> gas cooler 1= Centralized cabinet/cold room    15= analog positioner (4 to 20 mA) 2= Self contained cabinet/cold room    16= analog positioner (0 to 10 V) 3= Perturbated cabinet/control room    17= AC/chiller or cabinet/cold room with adaptative regulation 4= Subcritical CO <sub>2</sub> cabinet/cold room    18= AC or chiller with Digital Scroll compressor 5= R404A condenser for subcritical CO <sub>2</sub> 19= AC/chiller with BLDC compressor (*) 6= AC or chiller with plate evaporator    20= superheat regulation with 2 temperature probes 7= AC or chiller with shell tube evaporator    21= I/O expander for pCO 8= AC or chiller with battery coil evaporator    22= Programmable SH regulation 9= AC or chiller with variable cooling capacity    23= Programmable special regulation 10= AC or chiller perturbated unit    24= Programmable positioner 11= EPR Back pressure    25= Evaporator liquid level regulation with CAREL sensor 12= Hot gas by-pass by pressure    26= Condenser liquid level regulation with CAREL sensor 13= Hot gas by-pass by temperature    (*)= only for controls for CAREL valves	Multiplexed cabinet/cold room	-	-	-	I	15	142	
A	Probe S2: 0= user defined    1= NTC CAREL 2= CAREL NTC- HT high    3= combined NTC SPKP**T0 4= 0 to 10V external signal    5= NTC - LT CAREL low temperature	CAREL NTC	-	-	-	I	17	144	
A	Auxiliary control: 0= user defined 1= Disabled 2= high condensing temperature protection on S3 probe 3= modulating thermostat on S4 probe 4= backup probes on S3 and S4 5, 6, 7 = Reserved 8= Subcooling measurement 9= Inverse high condensation temperature protection on S3 probe 10= Reserved	Disabled	-	-	-	I	18	145	

User*	Parameter/description	Def.	Min.	Max.	UOM	Type**	CAREL SVP	Modbus®	Notes
A	Probe S3 0= user defined Ratiometric (OUT=0 to 5 V) 1= -1...4,2 barg 2= -0,4...9,3 barg 3= -1...9,3 barg 4= 0...17,3 barg 5= 0,85...34,2 barg 6= 0...34,5 barg 7= 0...45 barg 21= -1...12,8 barg 22= 0...20,7 barg 23= 1,86...43,0 barg 24= CAREL liquid level 25 = 0...60,0 barg 26 = 0...90,0 barg 27 = external signal 0...5 V	Electronic (OUT=4 to 20 mA) 8= -0,5...7 barg 9= 0...10 barg 10= 0...18,2 bar 11= 0...25 barg 12= 0...30 barg 13= 0...44,8 barg 14= remote, -0,5...7 barg 15= remote, 0...10 barg 16= remote, 0...18,2 barg 17= remote, 0...25 barg 18= remote, 0...30 barg 19= remote, 0...44,8 barg 20= 4...20 mA external signal	-	-	-	I	19	146	
A	Relay configuration: 1= Disabled 2= alarm relay (opened in case of alarm) 3= Solenoid valve relay (open in standby) 4= valve + alarm relay (opened in stand-by and control alarms) 5= Reversed alarm relay (closed in case of alarm) 6= Valve status relay (open if valve closed) 7= Direct command 8= Faulty closure alarm relay (opened if alarm) 9= Reverse faulty closure alarm relay (closed if alarm)	Alarm relay	-	-	-	I	12	139	
A	Probe S4: 0= User defined 1= CAREL NTC 2= CAREL NTC-HT high temperature 3= NTC built-in SPKP**T0 4= --- 5= NTC-LT CAREL low temperature	Not used	-	-	-	I	20	147	
A	DI2 configuration: 1= Disabled 2= valve regulation optimization after defrost 3= Battery alarm management 4= Valve forced open (at 100%) 5= Regulation start/stop 6= Regulation backup 7= Regulation security	Disabled	-	-	-	I	10	137	
C	Display main var. 1: 1= Valve opening 2= Valve position 3= Current cool. capacity 4= Control set point 5= Superheat 6= Suction temperature 7= Evaporation temperature 8= Evaporation pressure 9= Condensing temperature 10= Condensing pressure 11= Modulating thermostat temperature 12= EPR pressure	Superheat 13= Hot gas bypass pressure 14= Hot gas bypass temperature 15= CO <sub>2</sub> gas cooler outlet temperature 16= CO <sub>2</sub> gas cooler outlet pressure 17= CO <sub>2</sub> gas cooler pressure set point 18= S1 probe measurement 19= S2 probe measurement 20= S3 probe measurement 21= S4 probe measurement 22= 4-20 mA input value 23= 0-10 V input value	-	-	-	I	45	172	
C	Display main var. 2 (See display main var. 1)	Valve opening	-	-	-	I	46	173	
C	S1 probe alarm manag.: 1= No action 2= Valve forced closed 3= Valve at fixed posit. 4= Use backup probe S3	Valve at fixed position	-	-	-	I	24	151	
C	S2 probe alarm manag.: 1= No action 2= Valve forced closed 3= Valve at fixed posit. 4= Use backup probe S4	Valve at fixed position	-	-	-	I	25	152	
C	S3 probe alarm manag.: 1= No action 2= Valve forced closed 3= Valve at fixed posit.	No action	-	-	-	I	26	153	
C	S3 probe alarm manag.: 1= No action 2= Valve forced closed 3= Valve at fixed posit.	No action	-	-	-	I	27	154	
C	Unit of measure: °C/K/barg; °F/psig	°C(K), barg	-	-	-	I	21	148	
A	DI1 configuration 1= Disabled 2= Valve regulation optimization after defrost 3= Discharged battery alarm management 4= Valve forced open (at 100%) 5= Regulation start/stop 6= Regulation backup 7= Regulation security	Regulation start/stop (tLAN-RS485) / Regulation backup (pLAN)	-	-	-	I	85	212	
A	Language: Italian; English	English	-	-	-	-	-	-	

user*	Parameter/description	Def.	Min.	Max.	UOM	Type**	CARELSVP	Modbus®	Notes
C	Auxiliary refrigerant -1= user defined; 0 = same as main regulation 1= R22 2= R134a 3= R404A 4= R407C 5= R410A 6= R507A 7= R290 8= R600 9= R600a 10= R717 11= R744 12= R728 13= R1270 14= R417A 15= R422D 16= R413A 17= R422A 18= R423A 19= R407A 20= R427A 21= R245FA 22= R407F 23= R32 24= HTR01 25= HTR02 26= R23 27= R1234yf 28= R1234ze 29= R455A 30= R170 31= R442A 32= R447A 33= R448A 34= R449A 35= R450A 36= R452A 37= R508B 38= R452B 39= R513A 40= R454B 41= R458A 42= R407H 43= R454A 44= R454C 45= R470A 46= R515B 47= R466A	0	-	-	-	I	96	223	
<b>PROBES</b>									
C	S1 calibration offset	0	-60(-870)	60(870)	barq (psig)mA	A	34	33	
C	S1 calibrat gain on 4-20 mA	1	-20	20	-	A	36	35	
C	S1 pressure MINIMUM value	-1	-20 (-290)	S1 pressure MA- XIMUM value	barq (psig)	A	32	31	
C	S1 pressure MAXIMUM value	9.3	S1 pressure MINI- MUM value	200 (2900)	barq (psig)	A	30	29	
C	S1 alarm MIN pressure	-1	-20 (-290)	S1 alarm MAX pressure	barq (psig)	A	39	38	
C	S1 alarm MAX pressure	9.3	S1 alarm MIN pressure	200 (2900)	barq (psig)	A	37	36	
C	S2 calibration offset	0	-20 (-36), -20	20 (36), 20	°C (°F), volt	A	41	40	
C	S2 alarm MIN temperat	-50	-85(-121)	S2 alarm MAX temp.	°C (°F)	A	46	45	
C	S2 alarm MAX temperat	105	S2 alarm MIN temp.	200 (392)	°C (°F)	A	44	43	
C	S3 calibrat offset	0	60(-870)	60(870)	barq (psig)	A	35	34	
C	S3 calibration gain on 4 to 20 mA (cannot be selected)	1	-20	20	-	A	83	81	
C	S3 pressure MINIMUM value	-1	-20 (-290)	S3 pressure MA- XIMUM value	barq (psig)	A	33	32	
C	S3 pressure MAXIMUM value	9.3	S3 pressure MINI- MUM value	200 (2900)	barq (psig)	A	31	30	
C	S3 alarm MIN pressure	-1	-20 (-290)	S3 alarm MAX pressure	barq (psig)	A	40	39	
C	S3 probe alarm MAX pressure	9.3	S3 alarm MIN pressure	200 (2900)	barq (psig)	A	38	37	
C	S4 calibrat. offset	0	-20 (-36)	20 (36)	°C (°F)	A	42	41	
C	S4 alarm MIN temperat.	-50	-85(-121)	S4 alarm MAX temp.	°C (°F)	A	47	46	
C	S4 alarm MAX temperat.	105	S4 alarm MIN temp.	200 (392)	°C (°F)	A	45	44	
C	S1/S3 Maximum difference (pressure)	0	0	200(2900)	bar(psig)	A	114	113	
C	S2/S4 Maximum difference (temperature)	0	0	180(324)	°C (°F)	A	115	114	
C	Alarm delay S1	0	0	240	s	I	131	258	
C	Alarm delay S2	0	0	240	s	I	132	259	
C	Alarm delay S3	0	0	240	s	I	133	260	
C	Alarm delay S4	0	0	240	s	I	134	261	
C	Enable S1	1	0	1	-	D	16	15	
C	Enable S2	1	0	1	-	D	17	16	
C	Enable S3	1	0	1	-	D	18	17	
C	Enable S4	1	0	1	-	D	19	18	
C	Quick probe alarm disabling	0	0	1	-	D	66	65	
<b>CONTROL</b>									
A	Superheat set point	11	LowSH: threshold	180 (324)	K(°R)	A	50	49	
A	Valve opening at start-up	50	0	100	%	I	37	164	
C	Valve opened in standby (0=disabled=valve closed; 1=enabled = valve open according to parameter "Valve position in stand-by")	0	0	1	-	D	23	22	
C	Valve position in stand-by: 0 = 25%; 1...100% = % opening	0	0	100	%	I	91	218	
C	start-up delay after defrost	10	0	60	min	I	40	167	
A	Pre-position time	6	0	18000	s	I	90	217	
A	Hot gas bypass temperature set point	10	-85(-121)	200 (392)	°C (°F)	A	28	27	
A	Hot gas bypass pressure set point	3	-20 (-290)	200 (2900)	barq (psig)	A	62	61	
A	EPR pressure set point	3.5	-20 (-290)	200 (2900)	barq (psig)	A	29	28	
C	PID proportional gain	15	0	800	-	A	48	47	
C	PID integral time	150	0	1000	s	I	38	165	
C	PID derivative time	5	0	800	s	A	49	48	
A	LowSH protection threshold	5	-40 (-72)	superheat set point	K(°F)	A	56	55	
C	LowSH protection integral time	15	0	800	s	A	55	54	
A	LOP protection threshold	-50	-85(-121)	MOP protection threshold	°C (°F)	A	52	51	
C	LOP protection integral time	0	0	800	s	A	51	50	
A	MOP protection threshold	50	LOP protection threshold	200 (392)	°C (°F)	A	54	53	
C	MOP protection integral time	20	0	800	s	A	53	52	
A	Enable manual valve position	0	0	1	-	D	24	23	
A	Manual valve position	0	0	9999	step	I	39	166	
C	Discharge superheat setpoint	35	-40(-72)	180 (324)	K (°F)	A	100	99	
C	Discharge temperature setpoint	105	-85(-121)	200 (392)	°C (°F)	A	101	100	
C	Liquid level perc. set point	50	0	100	%	A	118	117	
<b>ADVANCED</b>									
A	High Tcond threshold	80	-85(-121)	200 (392)	°C (°F)	A	58	57	
C	High Tcond integral time	20	0	800	s	A	57	56	
A	Modul thermostat setpoint	0	-85(-121)	200 (392)	°C (°F)	A	61	60	
A	Modul thermostat differential	0, 1	0.1 (0.2)	100 (180)	°C (°F)	A	60	59	
C	Modul thermostat SHset offset	0	0 (0)	100 (180)	K (°F)	A	59	58	
C	CO <sub>2</sub> regul. 'A' coefficient	3.3	-100	800	-	A	63	62	
C	CO <sub>2</sub> regul. 'B' coefficient	-22.7	-100	800	-	A	64	63	

User*	Parameter/description	Def.	Min.	Max.	UOM	Type**	CAREL SVP	Modbus®	Notes
C	Network settings	2	0	30	bit/s	I	74	201	CO
	Parity								
	Bit di stop								
	Baud rate								
	0 no parity 2 stop bits 4800 bps								
	1 no parity 2 stop bits 9600 bps								
	2 no parity 2 stop bits 19200 bps								
	4 no parity 1 stop bit 4800 bps								
	5 no parity 1 stop bit 9600 bps								
	6 no parity 1 stop bit 19200 bps								
	16 even 2 stop bits 4800 bps								
	17 even 2 stop bits 9600 bps								
	18 even 2 stop bits 19200 bps								
	20 even 1 stop bit 4800 bps								
	21 even 1 stop bit 9600 bps								
	22 even 1 stop bit 19200 bps								
	24 odd 2 stop bits 4800 bps								
	25 odd 2 stop bits 9600 bps								
	26 odd 2 stop bits 19200 bps								
	28 odd 1 stop bit 4800 bps								
	29 odd 1 stop bit 9600 bps								
	30 odd 1 stop bit 19200 bps								
A	Power supply mode: 0= 24 Vac; 1= 24 Vdc	0	0	1	-	D	47	46	
C	Enable mode single on twin (parameter disabled): 0= Twin; 1= Single	0	0	1	-	D	58	57	
C	Stop manual positioning if net error: 0 = Normal operation; 1 = Stop	0	0	1	-	D	59	58	
C	Programmable regulation configuration	0	0	32767	-	I	101	228	
C	Programmable regulation input	0	0	32767	-	I	102	229	
C	Programmable SH regulation options	0	0	32767	-	I	103	230	
C	Programmable regulation set point	0	-800(-1233)	800(1233)	barq (psig)	A	112	111	
<b>CUSTOMIZED REFRIGERANT</b>									
	Dew a high	-288	-32768	32767	-	I	107	234	
	Dew a low	-15818	-32768	32767	-	I	108	235	
	Dew b high	-14829	-32768	32767	-	I	109	236	
	Dew b low	16804	-32768	32767	-	I	110	237	
	Dew c high	-11664	-32768	32767	-	I	111	238	
	Dew c low	16416	-32768	32767	-	I	112	239	
	Dew d high	-23322	-32768	32767	-	I	113	240	
	Dew d low	-16959	-32768	32767	-	I	114	241	
	Dew e high	-16378	-32768	32767	-	I	115	242	
	Dew e low	15910	-32768	32767	-	I	116	243	
	Dew f high	-2927	-32768	32767	-	I	117	244	
	Dew f low	-17239	-32768	32767	-	I	118	245	
	Bubble a high	-433	-32768	32767	-	I	119	246	
	Bubble a low	-15815	-32768	32767	-	I	120	247	
	Bubble b high	-15615	-32768	32767	-	I	121	248	
	Bubble b low	16805	-32768	32767	-	I	122	249	
	Bubble c high	30803	-32768	32767	-	I	123	250	
	Bubble c low	16416	-32768	32767	-	I	124	251	
	Bubble d high	-21587	-32768	32767	-	I	125	252	
	Bubble d low	-16995	-32768	32767	-	I	126	253	
	Bubble e high	-24698	-32768	32767	-	I	127	254	
	Bubble e low	15900	-32768	32767	-	I	128	255	
	Bubble f high	10057	-32768	32767	-	I	129	256	
	Bubble f low	-17253	-32768	32767	-	I	130	257	
C	Faulty closure alarm status 0/1=no/yes	0	0	1	-	D	49	48	
C	Battery charge delay	0	0	250	min	I	135	262	
<b>ALARMS CONFIGURATION</b>									
C	Low superheat alarm timeout (LowSH) (0= alarm DISABLED)	300	0	18000	s	I	43	170	
C	Low evap temp alarm timeout (LOP) (0= alarm DISABLED)	300	0	18000	s	I	41	168	
C	High evap temp alarm timeout (MOP) (0= alarm DISABLED)	600	0	18000	s	I	42	169	
C	High cond temp alarm timeout (High Tcond) (0= alarm DISABLED)	600	0	18000	s	I	44	171	
C	Low suction temperature alarm threshold	-50	-85 (-121)	200 (392)	°C(°F)	A	26	25	
C	Low suct temp alarm timeout (0= alarm DISABLED)	300	0	18000	s	I	9	136	
C	Alarm delay S1	0	0	240	s	I	131	258	
C	Alarm delay S2	0	0	240	s	I	132	259	
C	Alarm delay S3	0	0	240	s	I	133	260	
C	Alarm delay S4	0	0	240	s	I	134	261	
<b>VALVE</b>									
C	EEV minimum steps	50	0	9999	step	I	30	157	
C	EEV maximum steps	480	0	9999	step	I	31	158	
C	EEV closing steps	500	0	9999	step	I	36	163	
C	EEV nominal step rate	50	1	2000	step/s	I	32	159	
C	EEV nominal current	400	0	800	mA	I	33	160	
C	EEV holding current	100	0	250	mA	I	35	162	
C	EEV duty cycle	30	1	100	%	I	34	161	
C	EEV opening synchroniz.	1	0	1	-	D	20	19	
C	EEV closing synchroniz.	1	0	1	-	D	21	20	

Tab. 8.a

\* User: A= Service (installer), C= Manufacturer.

\*\*Type of variable: A= analogue, D= digital, I= integer

## 8.1 Unit of measure

In the configuration parameters menu, with access by manufacturer password, the user can choose the unit of measure for the driver:

- international system (°C, K, barg);
- imperial system (°F, psig).

**⚠ Important:** the drivers EVD evolution-pLAN (code EVD000E1\* and EVD000E4\*), connected in pLAN to a pCO controller, do not manage the change of the unit of measure.

**🔄 Note:** the unit of measure K relate to degrees Kelvin adopted for measuring the superheat and the related parameters.

When changing the unit of measure, all the values of the parameters saved on the driver and all the measurements read by the probes will be recalculated. This means that when changing the units of measure, control remains unaltered.

**Example 1:** The pressure read is 100 barg, this will be immediately converted to the corresponding value of 1450 psig.

**Example 2:** The "superheat set point" parameter set to 10 K will be immediately converted to the corresponding value of 18 °F.

**Example 3:** The "S4 alarm MAX temp." parameter, set to 150 °C, will be immediately converted to the corresponding value of 302 °F

**🔄 Note:** due to limits in the internal arithmetic of the driver, pressure values above 200 barg (2900 psig) and temperature values above 200 °C (392 °F) cannot be converted.

## 8.2 Variables accessible via serial connection

Description	Default	Min	Max	Type	CAREL SVP	Modbus®	R/W
Probe S1 reading	0	-20 (-290)	200 (2900)	A	1	0	R
Probe S2 reading	0	-85(-121)	200 (392)	A	2	1	R
Probe S3 reading	0	-20 (-290)	200 (2900)	A	3	2	R
Probe S4 reading	0	-85(-121)	200 (392)	A	4	3	R
Suction temperature	0	-85(-121)	200 (392)	A	5	4	R
Evaporation temperature	0	-85(-121)	200 (392)	A	6	5	R
Evaporation pressure	0	-85(-121)	200 (2900)	A	7	6	R
Hot gas bypass temperature	0	-85(-121)	200 (392)	A	8	7	R
EPR pressure (back pressure)	0	-20 (-290)	200 (2900)	A	9	8	R
Superheat	0	-40 (-72)	180 (324)	A	10	9	R
Condensing pressure	0	-20 (-290)	200 (2900)	A	11	10	R
Condensing temperature	0	-85(-121)	200 (392)	A	12	11	R
Modulating thermostat temperature	0	-85(-121)	200 (392)	A	13	12	R
Hot gas bypass pressure	0	-20 (-290)	200 (2900)	A	14	13	R
CO <sub>2</sub> gas cooler outlet pressure	0	-20 (-290)	200 (2900)	A	15	14	R
CO <sub>2</sub> gas cooler outlet temperature	0	-85(-121)	200 (392)	A	16	15	R
Valve opening	0	0	100	A	17	16	R
CO <sub>2</sub> gas cooler pressure set point	0	-20 (-290)	200 (2900)	A	18	17	R
4-20 mA input value	4	4	20	A	19	18	R
0-10 V input value	0	0	10	A	20	19	R
Control set point	0	-60 (-870)	200 (2900)	A	21	20	R
Driver firmware version	9.2**	0	10	A	25	24	R
MOP: suction temperature threshold (S2)	30	-85(-121)	200(392)	A	102	101	R/W
Discharge superheat	0	-40(-72)	180(324)	A	104	103	R
Discharge temperature	0	-85(-121)	200(392)	A	105	104	R
Thermal time constant NTC probe S4	50	1	800	A	106	105	R/W
MOP: High evaporation temperature threshold	50	LOP: threshold	200 (392)	A	107	106	R/W
Condensation pressure for subcooling measure	0	-20(-290)	200(2900)	A	108	107	R
Condensation bubble point	0	-85(-121)	200(392)	A	109	108	R
Condensation liquid temperature	0	-85(-121)	200(392)	A	110	109	R
Subcooling	0	-40(-72)	180(324)	A	111	110	R
Liquid regulation evaporator/ condenser level percentage	0	0	100	A	116	115	R
Valve position	0	0	9999	I	4	131	R
Current cooling capacity	0	0	100	I	7	134	R/W
Adaptive control status	0	0	6	I	75	202	R
Last tuning result	0	0	8	I	76	203	R
Extended measured probe S1 (*)	0	-2000 (-2901)	20000 (29007)	I	83	210	R
Extended measured probe S3 (*)	0	-2000 (-2901)	20000 (29007)	I	84	211	R
Valve emergency closing speed	150	1	2000	I	86	213	R/W
Control mode (BLDC comp.)	1	1	3	I	89	216	R/W
Type of unit for serial comm.	0	0	32767	I	94	221	R
HW code for serial comm.	0	0	32767	I	95	222	R
Reading of probe S1*40	0	-32768	32767	I	97	224	R
Reading of probe S2*40	0	-32768	32767	I	98	225	R
Reading of probe S3*40	0	-32768	32767	I	99	226	R
Reading of probe S4*40	0	-32768	32767	I	100	227	R

	Description	Default	Min	Max	Type	CAREL SVP	Modbus®	R/W
ALARMS	Low suction temperature	0	0	1	D	1	0	R
	LAN error	0	0	1	D	2	1	R
	EEPROM damaged	0	0	1	D	3	2	R
	Probe S1	0	0	1	D	4	3	R
	Probe S2	0	0	1	D	5	4	R
	Probe S3	0	0	1	D	6	5	R
	Probe S4	0	0	1	D	7	6	R
	EEV motor error	0	0	1	D	8	7	R
	Relay status	0	0	1	D	9	8	R
	PROTECT. ACTIVATED	LOP (low evaporation temperature)	0	0	1	D	50	49
MOP high evaporation temperature)		0	0	1	D	51	50	R
LowSH (low superheat)		0	0	1	D	52	51	R
HiTcond (high condensing temperature)		0	0	1	D	53	52	R
ALARMS	LOP (low evaporation temperature)	0	0	1	D	10	9	R
	MOP (high evaporation temperature)	0	0	1	D	11	10	R
	LowSH (low superheat)	0	0	1	D	12	11	R
	High Tcond (high condensing temperature)	0	0	1	D	13	12	R
	DI1 digital input status	0	0	1	D	14	13	R
AL.	DI2 digital input status	0	0	1	D	15	14	R
	Guided initial procedure completed	0	0	1	D	22	21	R/W
	Adaptive control ineffective	0	0	1	D	40	39	R
	Mains power failure	0	0	1	D	45	44	R
	DI Control backup	0	0	1	D	46	45	R/W
	Forced valve closing not completed	0	0	1	D	49	48	R/W
Direct relay control	0	0	1	D	57	56	R/W	
Enable LAN mode on service serial port (RESERVED)	0	0	1	D	60	59	R/W	

Tab. 8.b

(\*) The displayed variable is to be divided by 100, and allows us to appreciate the hundredth of a bar (psig).

Type of variable:

A= analogue,

D= digital,

I= integer

SVP= variable address with CAREL protocol on 485 serial card.

Modbus®: variable address with Modbus® protocol on 485 serial card.

\*\* or 9,3 for drivers for Carel valves only.

### 8.3 Variables used based on the type of control

The following table shows the variables used by the driver depending on the values of the Main control and Auxiliary control parameters. These variables can be shown on the display by accessing display mode (see paragraph 3.3 Display mode and via a serial connection with VPM, PlantVisorPRO. Proceed as follows to display the variables:

- press UP/DOWN;
- press the DOWN button to move to the next variable/screen;
- press Esc to return to the standard display.

Variable displayed	Main control													
	Superheat control													
	Auxiliary control			Subco- oling measure	Transcritical CO <sub>2</sub>	Hot gas by-pass /temperature	Hot gas by- pass / pressure	EPR back pressure	AC or chiller with Digital	Scroll compr.	AC/chiller with BLDC compres.	Superheat re- gulation with 2 temperature probes	I/O expander for pCO	Control with level sensor
HiTcond/ HiTcond inverse	Modulat. thermostat													
Valve opening(%)	•	•	•		•	•	•	•	•	•	•	•	•	•
Valve position (step)	•	•	•		•	•	•	•	•	•	•	•	•	•
Current unit cooling capacity	•	•	•		•	•	•	•	•	•	•	•	•	•
Control setpoint	•	•	•		•	•	•	•	•	•	•	•	•	•
Superheat	•	•	•		•	•	•	•	•	•	•	•	•	•
Suction temperature	•	•	•		•	•	•	•	•	•	•	•	•	•
Evaporation temperature	•	•	•		•	•	•	•	•	•	•	•	•	•
Evaporation pressure	•	•	•		•	•	•	•	•	•	•	•	•	•
Condensing temperature	•	•	•		•	•	•	•	•	•	•	•	•	•
Condensing pressure	•	•	•		•	•	•	•	•	•	•	•	•	•
Modulating thermostat temperature		•												
EPR pressure (back pressure)								•						
Hot gas bypass pressure							•							
Hot gas bypass temperature						•								
CO <sub>2</sub> gas cooler outlet temperature					•									
CO <sub>2</sub> gas cooler outlet pressure					•									
CO <sub>2</sub> gas cooler pressure set point					•									
Condensation pressure for subcooling measure (SBC)				•										
Condensation Temperature bubble for subcooling measure (SBC)				•										
Liquid temperature for subcooling measure (SBC)				•										
Subcooling measurement				•										
S1 probe measurement	•	•	•		•	•	•	•	•	•	•	•	•	•
S2 probe measurement	•	•	•		•	•	•	•	•	•	•	•	•	•
S3 probe measurement	•	•	•		•	•	•	•	•	•	•	•	•	•
S4 probe measurement	•	•	•		•	•	•	•	•	•	•	•	•	•
4 to 20 mA input value								•						
0 to 10 Vdc input value								•						
DI1 digital input status (*)	•	•	•		•	•	•	•	•	•	•	•	•	•
DI2 digital input status (*)	•	•	•		•	•	•	•	•	•	•	•	•	•
EVD firmware version	•	•	•		•	•	•	•	•	•	•	•	•	•
Display firmware version	•	•	•		•	•	•	•	•	•	•	•	•	•
Adaptative regulation status	•	•	•											
0= Not enabled or stopped														
1= Monitoring superheat														
2= Monitoring suction temperature														
3= Wait superheat stabilisation														
4= Wait suction temperature stabilisation														
5= Applying step														
6= Positioning valve														
7= Sampling response to step														
8=Wait stabilisation in response to step														
9= Wait tuning improvement														
10= Stop, max attempts exceeded														
Last tuning result	•	•	•											
0= No attempt performed														
1= Attempt interrupted														
2= Step application error														
3= Time constant/delay error														
4= Model error														
5= Tuning ended successfully on suction temperature														
6= Tuning ended successfully on superheat														
Discharge superheat										•				
Discharge temperature										•				
Liquid level percentage														•

Tab. 8.c

(\*) Digital input status: 0= open, 1= closed.

 **Note:** the readings of probes S1, S2, S3, S4 are always displayed, regardless of whether or not the probe is connected.

## 9. ALARMS

### 9.1 Alarms

There are two types of alarms:

- system: valve motor, EEPROM, probe and communication;
- control: low superheat, LOP, MOP, high condensing temperature, low suction temperature.

The activation of the alarms depends on the setting of the threshold and activation delay (timeout) parameters. Setting the timeout to 0 disables the alarms. The EEPROM unit parameters and operating parameters alarm always stops control.

All the alarms are reset automatically, once the causes are no longer present. The alarm relay contact will open if the relay is configured as alarm relay using the corresponding parameter. The signalling of the alarm event on the driver depends on whether the LED board or the display board is fitted, as shown in the table below.

**Note:** the alarm LED only comes on for the system alarms, and not for the control alarms.

**Example:** display system alarm on LED board:

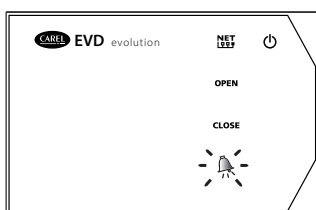

Fig. 9.a

**Note:** the alarm LED comes on to signal a mains power failure only if the EVBAT\*\*\* module (accessory) has been connected, guaranteeing the power required to close the valve.

The display shows both types of alarms, in two different modes:

- **system alarm:** on the main page, the ALARM message is displayed, flashing. Pressing the Help button displays the description of the alarm and, at the top right, the total number of active alarms.

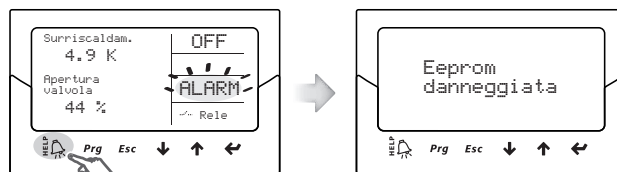

Fig. 9.b

- **control alarm:** next to the flashing ALARM message, the main page shows the type of protector activated.

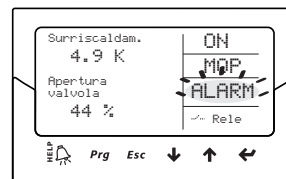

Fig. 9.c

- **Note:**
  - to display the alarm queue, press the Help button and scroll using the UP/DOWN buttons;
  - the control alarms can be disabled by setting the corresponding timeout to zero.

### Table of alarms

Type of alarm	Cause of alarm	LED	Display	Relay	Reset	Effect on control	Checks/ solutions
Probe S1	Probe S1 faulty or exceeded set alarm range	red alarm LED	ALARM flashing	Depends on configuration parameter	automatic	Depends on parameter "S1 probe alarm manag."	Check the probe connections. Check the "S1 probe alarm manag.", and "S1 alarm MIN & MAX pressure" parameters
Probe S2	Probe S2 faulty or exceeded set alarm range	red alarm LED	ALARM flashing	Depends on configuration parameter	automatic	Depends on parameter "S2 probe alarm manag."	Check the probe connections. Check the "S2 probe alarm manag.", and "S2 alarm MIN & MAX temperature" parameters
Probe S3	Probe S3 faulty or exceeded set alarm range	red alarm LED	ALARM flashing	Depends on configuration parameter	automatic	Depends on parameter "S3 probe alarm manag."	Check the probe connections. Check the "S3 probe alarm manag.", and "S3 alarm MIN & MAX pressure" parameters
Probe S4	Probe S4 faulty or exceeded set alarm range	red alarm LED	ALARM flashing	Depends on configuration parameter	automatic	Depends on parameter "S4 probe alarm manag."	Check the probe connections. Check the "S4 probe alarm manag.", and "S4 alarm MIN & MAX temperature" parameters
(LowSH) low superheat	LowSH protection activated	-	ALARM & LowSH flashing	Depends on configuration parameter	automatic	Protection action already active	Check the "LowSH alarm threshold and timeout" parameters
(LOP) low evaporation temperature	LOP protection activated	-	ALARM & LOP flashing	Depends on configuration parameter	automatic	Protection action already active	Check the "LOP alarm threshold and timeout" parameters
(MOP) high evaporation temperature	MOP protection activated	-	ALARM & MOP flashing	Depends on configuration parameter	automatic	Protection action already active	Check the "MOP alarm threshold and timeout" parameters"
(High Tcond) high condensation temperature	High Tcond protection activated	-	ALARM & MOP flashing	Depends on configuration parameter	automatic	Protection action already active	Check the "Hitcond alarm threshold and timeout" parameters"
Low suction temperature	Threshold and timeout exceeded	-	ALARM flashing	Depends on configuration parameter	automatic	No effect	Check the threshold and timeout parameters.
EEPROM damaged	EEPROM for operating and/or unit parameters damaged	red alarm LED	ALARM flashing	Depends on configuration parameter	Replace driver/Contact service	Total shutdown	Replace the driver/Contact service
EEV motor error	Valve motor fault, not connected	red alarm LED	ALARM flashing	Depends on configuration parameter	automatic	Interruption	Check the connections and the condition of the motor Switch driver off and on again
LAN error	LAN network communication error	green NET LED flashing	ALARM flashing	Depends on configuration parameter	automatic	Control based on DI1/DI2	Check the network address settings
	LAN network connection error	NET LED off	ALARM flashing	Depends on configuration parameter	automatic	Control based on DI1/DI2	Check the connections and that the pCO is on and working

Type of alarm	Cause of alarm	LED	Display	Relay	Reset	Effect on control	Checks/ solutions
Display connection error	No communication between driver and display	-	Error message	No change	replace the driver/display	No effect	Check the driver/display and the connectors
Adaptive control ineffective	Tuning failed	-	ALARM flashing	No change	automatic	No effect	Change "Main control" parameter setting
Battery discharged (**)	Battery discharged or faulty or electrical connection interrupted	red alarm LED flashing	Alarm flashing	No change	replace the battery	No effect	If the alarm persists for more than 3 hours (recharge time for EVBAT00500) replace the battery
Wrong power supply mode (*)	DC driver power supply with "Power supply mode" parameter set to AC power supply	Green PO-WER LED flashing Red alarm LED	-	Depends on the configuration parameter	Change "Power supply mode" parameter setting	Total shutdown	Check the "Power supply mode" parameter and power supply
Pressure difference	Maximum pressure difference threshold exceeded (S1-S3)	Red alarm LED	ALARM flashing	Depends on the configuration parameter	Automatic	Depends on the "Probe S1/S3 alarm management" parameters	Check the probe connections. Check the "Probe S1/S3 alarm management" and "Pressure S1/S3: MINIMUM and MAXIMUM alarm values" parameters
Temperature difference	Maximum pressure difference threshold exceeded (S2-S4)	Red alarm LED	ALARM flashing	Depends on the configuration parameter	Automatic	Depends on the "Probe S2/S4 alarm management" parameters	Check the probe connections. Check the "Probe S2/S4 alarm management" and "Temperature S2/S4: MINIMUM and MAXIMUM alarm values" parameters

Tab. 9.a

(\*) In the event of AC power supply with the "Power supply mode" parameter set to DC no alarm is displayed

(\*\*) Alarm only visible if driver connected to EVDBAT00400 battery module and digital input configured accordingly.

## 9.2 Alarm relay configuration

The relay contact is open when the driver is not powered. During normal operation, it can be disabled (and thus will be always open) or configured as:

- alarm relay: during normal operation, the relay contact is closed, and opens when any alarm is activated. It can be used to switch off the compressor and the system in the event of alarms.
- solenoid valve relay: during normal operation, the relay contact is closed, and is open only in standby. There is no change in the event of alarms.
- solenoid valve relay + alarm: during normal operation, the relay contact is closed, and opens in standby and/or for LowSH, MOP, High Tcond and low suction temperature alarms. This is because following such alarms, the user may want to protect the unit by stopping the flow of refrigerant or switching off the compressor.
- direct control: the relay is managed using a variable accessible via serial;
- failed closing alarm relay (open with alarm);
- reverse failed closing alarm relay (closed with alarm).

In the event of a mains power failure, if the driver is connected to the Ultracap module, the forced emergency valve closing procedure starts and the red LED comes. At the end of the emergency closing procedure, the outcome is indicated by the value of the parameter "Failed closing alarm status":

0 = Closing successful;

1 = Closing failed.

The driver will then switch off. If the closing procedure fails, when next restarting, if the parameter "Relay configuration" = 8 or 9 the display will show the "Battery discharged" alarm and the relay will be activated based on the setting (open or closed).



**Note:**

the "Battery discharged" alarm:

- has no affect on the positioning of the valve, it is signal-only;
- is not activated if the driver has a direct current power supply (Vdc).

Parameter/description	Def.
Relay configuration:	Alarm relay
1=Disabled	
2=alarm relay (opened in case of alarm)	
3=Solenoid valve relay (open in standby)	
4=valve + alarm relay (opened in stand-by and control alarms)	
5= Reversed alarm relay (closed in case of alarm)	
6= Valve status relay (open if valve is closed)	
7= Direct control	
8= Failed closing alarm relay(open with alarm)	
9= Reverse failed closing alarm relay (closed with alarm)	

Tab. 9.b

## 9.3 Probe alarms

The probe alarms are part of the system alarms. When the value measured by one of the probes is outside of the field defined by the parameters corresponding to the alarm limits, an alarm is activated. The limits can be set independently of the range of measurement. Consequently, the field outside of which the alarm is signalled can be restricted, to ensure greater safety of the controlled unit.



**Important:** in applications that use programmable control it may be necessary to exclude the alarms generated by the probes:

Parameter/description	Def.	Min.	Max.	UOM
PROBES				
Enable S1	1	0	1	-
Enable S2	1	0	1	-
Enable S3	1	0	1	-
Enable S4	1	0	1	-

Tab. 9.c

**Note:**

- the alarm limits can also be set outside of the range of measurement, to avoid unwanted probe alarms. In this case, the correct operation of the unit or the correct signalling of alarms will not be guaranteed;
- by default, after having selected the type of probe used, the alarm limits will be automatically set to the limits corresponding to the range of measurement of the probe.

Parameter/description	Def.	Min.	Max.	UOM
<b>PROBES</b>				
S1 alarm MIN pressure (S1_AL_MIN)	-1	-20 (-290)	S1_AL_MAX	barg (psig)
S1 alarm MAX pressure (S1_AL_MAX)	9.3	S1_AL_MIN	200 (2900)	barg (psig)
Alarm delay S1	0	0	240	s
S2 alarm MIN temp. (S2_AL_MIN)	-50	-60	S2_AL_MAX	°C/°F
S2 alarm MAX temp. (S2_AL_MAX)	105	S2_AL_MIN	200 (392)	°C (°F)
Alarm delay S2	0	0	240	s
S3 alarm MIN pressure (S3_AL_MIN)	-1	-20	S3_AL_MAX	barg (psig)
S3 alarm MAX pressure (S3_AL_MAX)	9.3	S3_AL_MIN	200 (2900)	barg (psig)
Alarm delay S3	0	0	240	s
S4 alarm MIN temp. (S4_AL_MIN)	-50	-60	S4_AL_MAX	°C/°F
S4 alarm MAX temp. (S4_AL_MAX)	105	S4_AL_MIN	200 (392)	°C (°F)
Alarm delay S4	0	0	240	s

Tab. 9.d

The behaviour of the driver in response to probe alarms can be configured, using the manufacturer parameters. The options are:

- no action (control continues but the correct measurement of the variables is not guaranteed);
- forced closing of the valve (control stopped);
- valve forced to the initial position (control stopped);
- use the backup probe (valid only for probe S1 and S2 alarms, control continues).

Parameter/description	Def.
<b>CONFIGURATION</b>	
S1 probe alarm manag.: 1=No action 2=Valve forced closed 3=Valve at fixed position 4=Use backup probe S3	Valve at fixed position
S2 probe alarm manag.: 1=No action 2=Valve forced closed 3=Valve at fixed position 4=Use backup probe S4	Valve at fixed position
S3 probe alarm manag.: 1=No action 2=Valve forced closed 3=Valve at fixed position	No action
S4 probe alarm manag.: 1=No action 2=Valve forced closed 3=Valve at fixed position	No action
<b>CONTROL</b>	
Valve opening at start-up (evaporator/valve capacity ratio)	ca- 50

Tab. 9.e

## 9.4 Control alarms

These are alarms that are only activated during regulation.

### Protector alarms

The alarms corresponding to the LowSH, LOP, MOP and High Tcond protectors are only activated during control when the corresponding activation threshold is exceeded, and only when the timeout defined by the corresponding parameter has elapsed. If a protector is not enabled (integration time= 0 s), no alarm will be signalled. If before the expiry of the timeout, the protector control variable returns back inside the corresponding threshold, no alarm will be signalled.

**Note:** this is a likely event, as during the timeout, the protection function will have an effect.

If the timeout relating to the control alarms is set to 0 s, the alarm is disabled. The protectors are still active, however. The alarms are reset automatically.

### Low suction temperature alarm

The low suction temperature alarm is not linked to any protection function. It features a threshold and a timeout, and is useful in the event of probe or valve malfunctions to protect the compressor using the relay to control the solenoid valve or to simply signal a possible risk. In fact, the incorrect measurement of the evaporation pressure or incorrect configuration of the type of refrigerant may mean the superheat calculated is much higher than the actual value, causing an incorrect and excessive opening of the valve. A low suction temperature measurement may in this case indicate the probable flooding of the compressor, with corresponding alarm signal. If the alarm timeout is set to 0 s, the alarm is disabled. The alarm is reset automatically, with a fixed differential of 3°C above the activation threshold.

### Relay activation for control alarms

As mentioned in the paragraph on the configuration of the relay, in the event of LowSH, MOP, High Tcond and low suction temperature alarms, the driver relay will open both when configured as an alarm relay and configured as a solenoid + alarm relay. In the event of LOP alarms, the driver relay will only open if configured as an alarm relay.

Parameter/description	Def.	Min.	Max.	UOM
<b>CONTROL</b>				
LowSH protection threshold	5	-40 (-72)	superheat set point	K (°F)
LowSH protection integration time	15	0	800	s
LOP protection threshold	-50	-60 (-76)	MOP threshold	°C (°F)
LOP protection integration time	0	0	800	s
MOP protection threshold	50	LOP threshold.	200 (392)	°C (°F)
MOP protection integration time	20	0	800	s
<b>ADVANCED</b>				
High Tcond threshold	80	-60 (-76)	200 (392)	°C (°F)
High Tcond integration time	20	0	800	s
<b>ALARM CONFIGURATION</b>				
Low superheat alarm timeout (LowSH) (0= alarm DISABLED)	300	0	18000	s
Low evaporation temperature alarm timeout (LOP) (0= alarm DISABLED)	300	0	18000	s
High evaporation temperature alarm timeout (MOP) (0= alarm DISABLED)	600	0	18000	s
High condensing temperature alarm timeout (High Tcond) (0= alarm DISABLED)	600	0	18000	s
Low suction temperature alarm threshold	-50	-60 (-76)	200 (392)	°C (°F)
Low suction temperature alarm timeout	300	0	18000	s

## 9.5 EEV motor alarm

At the end of the commissioning procedure and whenever the driver is powered up, the valve motor error recognition procedure is activated. This precedes the forced closing procedure and lasts around 10 s. The valve is kept stationary to allow any valve motor faults or missing or incorrect connections to be detected. In any of these cases, the corresponding alarm is activated, with automatic reset. The driver will go into wait status, as it can no longer control the valve. The procedure can be avoided by keeping the respective digital input closed for each driver. In this case, after having powered up the driver, forced closing of the valve is performed immediately.

 **Important:** after having resolved the problem with the motor, it is recommended to switch the driver off and on again to realign the position of the valve. If this is not possible, the automatic procedure for synchronising the position may help solve the problem, nonetheless correct regulation will not be guaranteed until the next synchronisation.

## 9.6 LAN error alarm

 **Note:** in the event of LAN error, a parameter can be set to disable "Manual positioning".

If the connection to the LAN network is offline for more than 6s due to an electrical problem, the incorrect configuration of the network addresses or the malfunction of the pCO controller, a LAN error alarm will be signalled.

The error affects the control of the driver as follows:

- **case 1:** unit in standby, digital input DI1/DI2 disconnected; the driver will remain permanently in standby and control will not be able to start;
- **case 2:** unit in control, digital input DI1/DI2 disconnected: the driver will stop control and will go permanently into standby;
- **case 3:** unit in standby, digital input DI1/DI2 connected: the driver will remain in standby, however control will be able to start if the digital input is closed. In this case, it will start with "current cooling capacity" = 100%;
- **case 4:** unit in control, digital input DI1/DI2 connected: the driver will remain in control status, maintaining the value of the "current cooling capacity". If the digital input opens, the driver will go to standby and control will be able to start again when the input closes. In this case, it will start with "current cooling capacity" = 100%

## 10. TROUBLESHOOTING

The following table lists a series of possible malfunctions that may occur when starting and operating the driver and the electronic valve. These cover the most common problems and are provided with the aim of offering an initial response for resolving the problem.

PROBLEM	CAUSE	SOLUTION
The superheat value measured is incorrect	The probe does not measure correct values	Check that the pressure and the temperature measured are correct and that the probe position is correct. Check that the minimum and maximum pressure parameters for the pressure transducer set on the driver correspond to the range of the pressure probe installed. Check the correct probe electrical connections.
Liquid returns to the compressor during control	The type of refrigerant set is incorrect	Check and correct the type of refrigerant parameter.
	The type of valve set is incorrect	Check and correct the type of valve parameter.
	The valve is connected incorrectly (rotates in reverse) and is open	Check the movement of the valve by placing it in manual control and closing or opening it completely. One complete opening must bring a decrease in the superheat and vice-versa. If the movement is reversed, check the electrical connections.
	The superheat set point is too low	Increase the superheat set point. Initially set it to 12 °C and check that there is no longer return of liquid. Then gradually reduce the set point, always making sure there is no return of liquid.
	Low superheat protection ineffective	If the superheat remains low for too long with the valve that is slow to close, increase the low superheat threshold and/or decrease the low superheat integration time. Initially set the threshold 3 °C below the superheat set point, with an integration time of 3-4 seconds. Then gradually lower the low superheat threshold and increase the low superheat integration time, checking that there is no return of liquid in any operating conditions.
	Stator broken or connected incorrectly	Disconnect the stator from the valve and the cable and measure the resistance of the windings using an ordinary tester. The resistance of both should be around 36 ohms. Otherwise replace the stator. Finally, check the electrical connections of the cable to the driver.
Liquid returns to the compressor only after defrosting (for multiplexed cabinets only)	Valve stuck open	Check if the superheating is always low (<2 °C) with the valve position permanently at 0 steps. If so, set the valve to manual control and close it completely. If the superheat is always low, check the electrical connections and/or replace the valve.
	The "valve opening at start-up" parameter is too high on many cabinets in which the control set point is often reached (for multiplexed cabinets only)	Decrease the value of the "Valve opening at start-up" parameter on all the utilities, making sure that there are no repercussions on the control temperature.
	The pause in control after defrosting is too short	Increase the value of the "valve control delay after defrosting" parameter.
	The superheat temperature measured by the driver after defrosting and before reaching operating conditions is very low for a few minutes	Check that the LowSH threshold is greater than the superheat value measured and that the corresponding protection is activated (integration time >0 s). If necessary, decrease the value of the integration time.
Liquid returns to the compressor only when starting the controller (after being OFF)	The superheat temperature measured by the driver does not reach low values, but there is still return of liquid to the compressor rack Many cabinets defrosting at the same time	Set more reactive parameters to bring forward the closing of the valve: increase the proportional factor to 30, increase the integration time to 250 s and increase the derivative time to 10 sec. Stagger the start defrost times. If this is not possible, if the conditions in the previous two points are not present, increase the superheat set point and the LowSH thresholds by at least 2 °C on the cabinets involved.
	The valve is significantly oversized	Replace the valve with a smaller equivalent.
	The "valve opening at start-up" parameter is set too high	Check the calculation in reference to the ratio between the rated cooling capacity of the evaporator and the capacity of the valve; if necessary, lower the value.
The superheat value swings around the set point with an amplitude greater than 4°C	The condensing pressure swings	Check the controller condenser settings, giving the parameters "blander" values (e.g. increase the proportional band or increase the integration time). Note: the required stability involves a variation within +/- 0.5 bars. If this is not effective or the settings cannot be changed, adopt <b>electronic valve control parameters for perturbed systems</b>
	The superheat swings even with the valve set in manual control (in the position corresponding to the average of the working values)	Check for the causes of the swings (e.g. low refrigerant charge) and resolve where possible. If not possible, adopt electronic valve control parameters for perturbed systems.
	The superheat does NOT swing with the valve set in manual control (in the position corresponding to the average of the working values)	As a first approach, decrease (by 30 to 50 %) the proportional factor. Subsequently try increasing the integration time by the same percentage. In any case, adopt parameter settings recommended for stable systems.
	The superheat set point is too low	Increase the superheat set point and check that the swings are reduced or disappear. Initially set 13 °C, then gradually reduce the set point, making sure the system does not start swinging again and that the unit temperature reaches the control set point.
In the start-up phase with high evaporator temperatures, the evaporation pressure is high	MOP protection disabled or ineffective	Activate the MOP protection by setting the threshold to the required saturated evaporation temperature (high evaporation temperature limit for the compressors) and setting the MOP integration time to a value above 0 (recommended 4 seconds). To make the protection more reactive, decrease the MOP integration time.
	Refrigerant charge excessive for the system or extreme transitory conditions at start-up (for cabinets only).	Apply a "soft start" technique, activating the utilities one at a time or in small groups. If this is not possible, decrease the values of the MOP thresholds on all the utilities.

PROBLEM	CAUSE	SOLUTION
In the start-up phase the low pressure protection is activated (only for self-contained units)	The "Valve opening at start-up" parameter is set too low	Check the calculation in reference to the ratio between the rated cooling capacity of the evaporator and the capacity of the valve; if necessary increase the value.
	The driver in pLAN or tLAN configuration does not start control and the valve remains closed	Check the pLAN / tLAN connections. Check that the pCO application connected to the driver (where featured) correctly manages the driver start signal. Check that the driver is NOT in stand-alone mode.
	The driver in stand-alone configuration does not start control and the valve remains closed	Check the connection of the digital input. Check that when the control signal is sent that the input is closed correctly. Check that the driver is in stand-alone mode.
	LOP protection disabled	Set a LOP integration time greater than 0 s.
	LOP protection ineffective	Make sure that the LOP protection threshold is at the required saturated evaporation temperature (between the rated evaporation temperature of the unit and the corresponding temperature at the calibration of the low pressure switch) and decrease the value of the LOP integration time.
	Solenoid blocked	Check that the solenoid opens correctly, check the electrical connections and the operation of the relay.
	Insufficient refrigerant	Check that there are no bubbles in the sight glass upstream of the expansion valve. Check that the subcooling is suitable (greater than 5 °C); otherwise charge the circuit.
The unit switches off due to low pressure during control (only for self-contained units)	The valve is connected incorrectly (rotates in reverse) and is open	Check the movement of the valve by placing it in manual control and closing or opening it completely. One complete opening must bring a decrease in the superheat and vice-versa. If the movement is reversed, check the electrical connections.
	Stator broken or connected incorrectly	Disconnect the stator from the valve and the cable and measure the resistance of the windings using an ordinary tester. The resistance of both should be around 36 ohms. Otherwise replace the stator. Finally, check the electrical connections of the cable to the driver (see paragraph 5.1).
	Valve stuck closed	Use manual control after start-up to completely open the valve. If the superheat remains high, check the electrical connections and/or replace the valve.
	LOP protection disabled	Set a LOP integration time greater than 0 s.
	LOP protection ineffective	Make sure that the LOP protection threshold is at the required saturated evaporation temperature (between the rated evaporation temperature of the unit and the corresponding temperature at the calibration of the low pressure switch) and decrease the value of the LOP integration time.
	Solenoid blocked	Check that the solenoid opens correctly, check the electrical connections and the operation of the control relay.
	Insufficient refrigerant	Check that there are no bubbles of air in the liquid indicator upstream of the expansion valve. Check that the subcooling is suitable (greater than 5 °C); otherwise charge the circuit.
The cabinet does not reach the set temperature, despite the valve being opened to the maximum (for multiplexed cabinets only)	The valve is significantly undersized	Replace the valve with a larger equivalent.
	Stator broken or connected incorrectly	Disconnect the stator from the valve and the cable and measure the resistance of the windings using an ordinary tester. The resistance of both should be around 36 ohms. Otherwise replace the stator. Finally, check the electrical connections of the cable to the driver.
	Valve stuck closed	Use manual control after start-up to completely open the valve. If the superheat remains high, check the electrical connections and/or replace the valve.
	Solenoid blocked	Check that the solenoid opens correctly, check the electrical connections and the operation of the relay.
	Insufficient refrigerant	Check that there are no bubbles of air in the liquid indicator upstream of the expansion valve. Check that the subcooling is suitable (greater than 5 °C); otherwise charge the circuit.
	The valve is significantly undersized	Replace the valve with a larger equivalent.
	Stator broken or connected incorrectly	Disconnect the stator from the valve and the cable and measure the resistance of the windings using an ordinary tester. The resistance of both should be around 36 ohms. Otherwise replace the stator. Finally, check the electrical connections of the cable to the driver.
The cabinet does not reach the set temperature, and the position of the valve is always 0 (for multiplexed cabinets only)	Valve stuck closed	Use manual control after start-up to completely open the valve. If the superheat remains high, check the electrical connections and/or replace the valve.
	The driver in pLAN or tLAN configuration does not start control and the valve remains closed	Check the pLAN/tLAN connections. Check that the pCO application connected to the driver (where featured) correctly manages the driver start signal. Check that the driver is NOT in stand-alone mode.
	The driver in stand-alone configuration does not start control and the valve remains closed	Check the connection of the digital input. Check that when the control signal is sent that the input is closed correctly. Check that the driver is in stand-alone mode.

Tab. 10.a

# 11. TECHNICAL SPECIFICATIONS

Power supply (Lmax= 5 m)		<ul style="list-style-type: none"> <li>• 24 Vac (+10/-15%) to be protected by external 2 A type T fuse.</li> <li>• 24 Vdc (+10/-15%) to be protected by external 2 A type T fuse. Use a dedicated class 2 transformer (max 100 VA).</li> </ul>
Power input		<ul style="list-style-type: none"> <li>• 16.2 W with ALCO EX7/EX8 valves, 9.2 W with all other valves</li> <li>• 35 VA with EVBAT00400; 35 VA with ALCO EX7/EX8 valves; 20 VA without EVBAT00400 and with all other valves</li> </ul>
Emergency power supply		22 Vdc+/-5%. (If the optional EVBAT00200/300 module is installed), Lmax= 5 m
Insulation between relay output and other outputs		reinforced; 6 mm in air, 8 mm on surface; 2900V insulation
Motor connection		4-wire shielded cable i.e. CAREL code E2VCABS*00, or 4-wire shielded cable AWG 22 Lmax= 10 m; or 4-wire shielded cable AWG 14 Lmax= 50 m
Digital input connection		Digital input to be activated from voltage-free contact or transistor to GND. Closing current 5 mA; Lmax= 30 m
Probes (Lmax=10 m; less than 30 m with shielded cable)	S1	<p>ratiometric pressure probe (0 to 5 V):</p> <ul style="list-style-type: none"> <li>• resolution 0.1 % FS; • measurement error: 2% FS maximum; 1% typical</li> </ul> <p>electronic pressure probe (4 to 20 mA):</p> <ul style="list-style-type: none"> <li>• resolution 0.5 % FS; • measurement error: 8% FS maximum; 7% typical</li> </ul> <p>remote electronic pressure probe(4 to 20 mA), maximum number of drivers connected= 5:</p> <ul style="list-style-type: none"> <li>• resolution 0.1 % FS; • measurement error: 2 % FS maximum; 1 % typical</li> </ul> <p>4 to 20 mA input (max 24 mA):</p> <ul style="list-style-type: none"> <li>• resolution 0.5 % FS; • measurement error: 8% FS maximum; 7% typical</li> </ul> <p>0 to 5 V input:</p> <ul style="list-style-type: none"> <li>• resolution 0.1 % FS; • measurement error: 2% FS maximum; 1% typical</li> </ul>
	S2	<p>low temperature NTC:</p> <ul style="list-style-type: none"> <li>• 10kΩ at 25°C, -50T90 °C; • measurement error: 1°C in the range -50T50°C; 3 °C in the range +50T90 °C</li> </ul> <p>high temperature NTC:</p> <ul style="list-style-type: none"> <li>• 50kΩ at 25°C, -30T150°C; • measurement error: 1.5 °C in the range -20T115°C, 4 °C in the range outside of -20T115 °C</li> </ul> <p>NTC built-in:</p> <ul style="list-style-type: none"> <li>• 10kΩ at 25 °C, -40T120 °C; • measurement error: 1 °C in the range -40T50°C; 3 °C in the range +50T90 °C</li> </ul> <p>0 to 10 V input (max 12 V):</p> <ul style="list-style-type: none"> <li>• resolution 0.1 % FS; • measurement error: 9% FS maximum; 8% typical</li> </ul>
	S3	<p>ratiometric pressure probe (0 to 5 V):</p> <ul style="list-style-type: none"> <li>• resolution 0.1 % FS; • measurement error: 2% FS maximum; 1% typical</li> </ul> <p>electronic pressure probe (4 to 20 mA):</p> <ul style="list-style-type: none"> <li>• resolution 0.5 % FS; • measurement error: 8% FS maximum; 7% typical</li> </ul> <p>electronic pressure probe (4 to 20 mA) remote. Maximum number of controllers connected=5</p> <p>combined ratiometric pressure probe (0 to 5 V):</p> <ul style="list-style-type: none"> <li>• resolution 0.1 % FS • measurement error: 2 % FS maximum; 1 % typical</li> </ul> <p>0 to 5 V input:</p> <ul style="list-style-type: none"> <li>• resolution 0.1 % FS; • measurement error: 2% FS maximum; 1% typical</li> </ul>
	S4	<p>low temperature NTC:</p> <ul style="list-style-type: none"> <li>• 10kΩ at 25°C, -50T105 °C; • measurement error: 1 °C in the range -50T50 °C; 3°C in the range 50T90°C</li> </ul> <p>high temperature NTC:</p> <ul style="list-style-type: none"> <li>• 50kΩ at 25 °C, -30T150°C; • measurement error: 1.5 °C in the range -20T115 °C 4 °C in the range outside of -20T115 °C</li> </ul> <p>NTC built-in:</p> <ul style="list-style-type: none"> <li>• 10kΩ at 25 °C, -40T120 °C; • measurement error 1 °C in the range -40T50 °C; 3 °C in the range +50T90 °C</li> </ul>
Relay output		normally open contact; 5 A, 250 Vac resistive load; 2 A, 250 Vac inductive load (PF=0.4); Lmax=10 m; VDE: 1(1)A PF=0.6
Power to active probes (V <sub>pp</sub> )		programmable output: +5 Vdc+/-2% or 12 Vdc+/-10%
RS485 serial connection		Lmax=1000 m, shielded cable
rLAN connection		Lmax=30 m, shielded cable
pLAN connection		Lmax=500 m, shielded cable
Assembly		DIN rail
Connectors		plug-in, cable size 0.5 to 2.5 mm <sup>2</sup> (12 to 20 AWG)
Dimensions		LxHxW= 70x110x60
Operating conditions		-25T60°C (don't use EVDIS* under -20°C); <90% RH non-condensing
Storage conditions		-35T60°C (don't store EVDIS* under -30°C), humidity 90% RH non-condensing
Index of protector		IP20
Environmental pollution		3 (normal)
Resistance to heat and fire		Category D
Immunity against voltage surges		Class III
Rated impulse voltage		4000V
Type of relay action		1C microswitching
Class of protection against electric shock		To be incorporated in class I or II appliances
Software class and structure		A
Conformity		Electrical safety: EN 60730-1, EN 61010-1; UL 60730-1 Electromagnetic compatibility: EN 61000-6-1, EN 61000-6-2, EN 61000-6-3, EN 61000-6-4; EN61000-3-2, EN55014-1, EN55014-2, EN61000-3-3.
Flammable refrigerants		EVD Evolution complies with standard IEC 60335-2-40:2018 in case of using A2L refrigerants (e.g. R32); in detail, electrical components that could be a source of ignition under normal operation are in compliance with Annex JJ, and the maximum surface temperature of all components does not exceed values given in Annex BB for A2L refrigerants reduced by 100K, during normal operation.

Tab. 11.a

## 12. APPENDIX: VPM (VISUAL PARAMETER MANAGER)

### 12.1 Installation

On the <http://ksa.carel.com> website, under the Parametric Controller Software section, select Visual Parameter Manager.

A window opens, allowing 3 files to be downloaded:

1. VPM\_CD.zip: for burning to a CD;
2. Upgrade setup;
3. Full setup: the complete program.

For first installations, select Full setup, for upgrades select Upgrade setup. The program is installed automatically, by running setup.exe.

**Note:** if deciding to perform the complete installation (Full setup), first uninstall any previous versions of VPM.

### 12.2 Programming (VPM)

When opening the program, the user needs to choose the device being configured: EVD evolution. The Home page then opens, with the choice to create a new project or open an existing project. Choose new project and enter the password, which when accessed the first time can be set by the user.

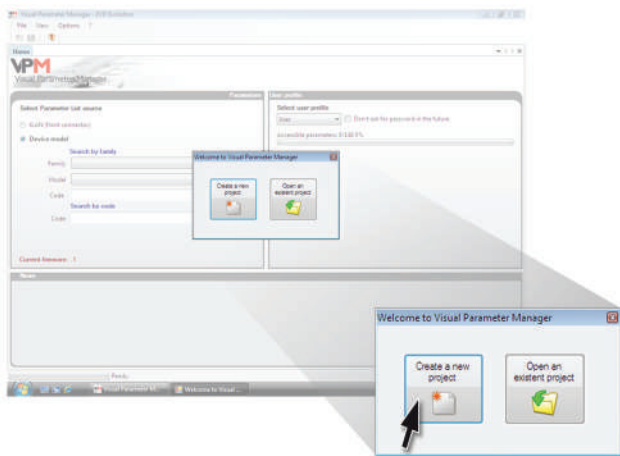

Fig. 12.a

Then the user can choose to:

4. directly access to the list of parameters for the EVD evolution saved to EEPROM: select "tLAN";

This is done in real time (ONLINE mode), at the top right set the network address 198 and choose the guided recognition procedure for the USB communication port. Enter at the Service or Manufacturer level.

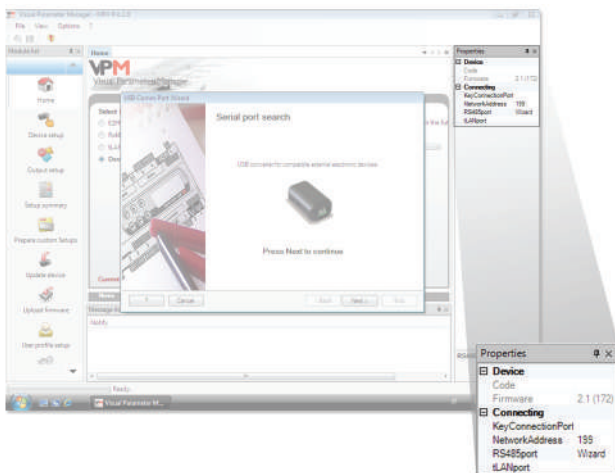

Fig. 12.b

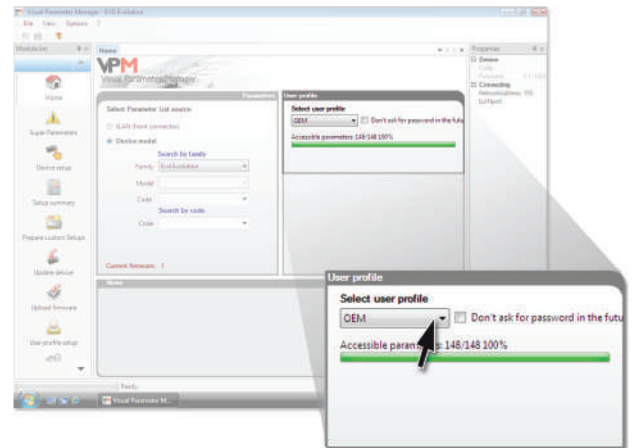

Fig. 12.c

5. select the model from the range and create a new project or choose an existing project: select "Device model".

A new project can be created, making the changes and then connecting later on to transfer the configuration (OFFLINE mode). Enter at the Service or Manufacturer level.

- select Device model and enter the corresponding code

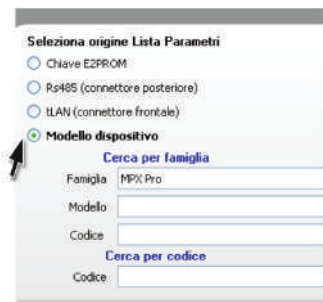

Fig. 12.d

- go to Configure device: the list of parameters will be displayed, allowing the changes relating to the application to be made.

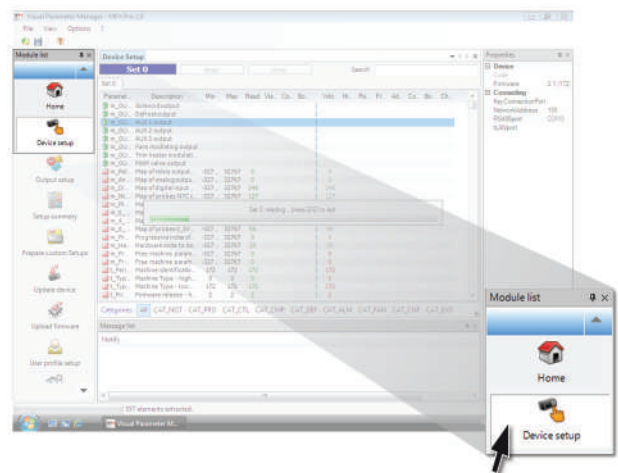

Fig. 12.e

At the end of the configuration, to save the project choose the following command, used to save the configuration as a file with the .hex extension.

File -> Save parameter list.

To transfer the parameters to the driver, choose the "Write" command. During the write procedure, the 2 LEDs on the converter will flash.







# CAREL

**CAREL INDUSTRIES HeadQuarters**  
Via dell'Industria, 11 - 35020 Brugine - Padova (Italy)  
Tel. (+39) 049.9716611 - Fax (+39) 049.9716600  
e-mail: carel@carel.com - www.carel.com

Agenzia / Agency: