



Thermo™ - Expansion Valves

Basic Terms and Technical Information

Operating Principles

Alco Thermo-Expansion valves control the superheat of refrigerant vapor at the outlet of the evaporator. They act as a throttle device between the high pressure and the low pressure sides of refrigeration systems and ensure that the rate of refrigerant flow into the evaporator exactly matches the rate of evaporation of liquid refrigerant in the evaporator. Thus the evaporator is fully utilized and no liquid refrigerant may reach the compressor.

Description of Bulb Charges

The application ranges of Thermo-Expansion valves are heavily influenced by the charge selected.

Liquid Charges

The behaviour of Thermo-Expansion valves with liquid charges is exclusively determined by temperature changes at the bulb and not subject to any cross-ambient interference. They feature a fast response time and thus react quickly in the control circuit. Liquid charges cannot incorporate MOP functions. Maximum bulb temperatures shall not exceed 75°C.

Gas Charges

The behaviour of Thermo-Expansion valves with gas charges will be determined by the lowest temperature at any part of the expansion valve (power assembly, capillary tube or bulb). If any parts other than the bulb are subject to the lowest temperature, malfunction of the expansion valve may occur (i.e., erratic low pressure or excessive superheat). Alco Thermo-Expansion valves with gas charges always feature MOP functions and include ballasted bulbs. Ballast in the bulb leads to slow opening and fast closure of the valve. Maximum bulb temperature is 120°C.

Adsorption Charges

These charges feature control characteristics much like MOP charges but avoid the difficulties of cross-ambient interference. Response time is slow but perfectly suitable for common refrigeration systems. Maximum bulb temperature is 130°C.

MOP (Maximum Operating Pressure)

MOP functionality is somewhat similar to the application of a crankcase pressure regulator. Evaporator pressures are limited to a maximum value to protect compressor from overload conditions. MOP selection should be within maximum allowed low pressure rating of the compressor and should be at approximately 3K above evaporating temperatures.

Practical hint: superheat adjustments influence the MOP:

Increase of superheat:	Decrease of MOP
Decrease of superheat:	Increase of MOP

Static Superheat

Alco Thermo-Expansion valves are factory preset for optimum superheat settings. This setting should be modified only if absolutely necessary. The readjustment should be at the lowest expected evaporating temperature.



Subcooling

Subcooling generally increases the capacity of the refrigeration system and may be accounted for when dimensioning an expansion valve by applying the correction factor K_c . The capacity corrections for evaporating temperature, condensing temperature and subcooling are all incorporated in K_c . These are, in particular the liquid density upstream from the expansion valve, the different enthalpies of liquid and vapor phase refrigerants, as well as certain parts of flash gas after expansion. The percentage of flash gas differs with various refrigerants and depends on system conditions.

Heavy subcooling results in very small flash gas amounts and therefore increases expansion valve capacities. These conditions are not covered by K_c . Likewise, small flash gas amounts lead to reduced evaporator capacities and may result in substantial discrepancies between the capacities of the Thermo-expansion valve and the evaporator. These effects have been integrated in selection program “Controls Navigator”.

Dimensioning

To facilitate valve dimensioning for other than standard conditions, Emerson offers the “Controls Navigator” selection tool which can be downloaded from climate.emerson.com/en-gb.

See climate.emerson.com/en-gb for contact addresses, email, phone numbers or downloads.

Dimensioning of Thermo™ - Expansion Valves for Systems with Refrigerant Having Temperature Glide

As opposed to single substances (e.g. R 134a) where the phase change takes place at a constant temperature/pressure the evaporation and condensation of zeotropic blends are in a "gliding" form (e.g. at a constant pressure the temperature varies within a certain range) through evaporators and condensers. HFO blends R448A and R449A are zeotropic blends.

The condensing /evaporating pressure must be determined at saturated temperatures (bubble for liquid / dew points for vapor) for dimensioning of the expansion valves, solenoid valves etc. The corresponding dew point for liquid pressures is provided in case of compressor selection based on dew point of liquid pressure.

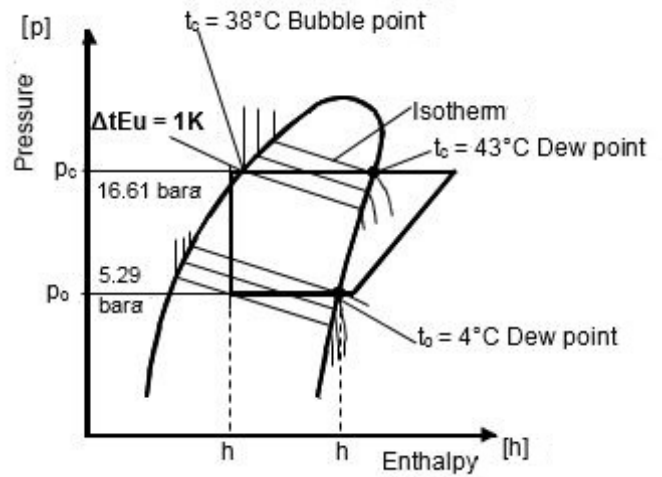

Selection Table for Expansion Valves

Series	Selection Criteria			
	Capacity Range R448A (kW)	Evaporating Temp. Range (°C)	Main Application	Features
TI	0.5...19.4	+20...-45	Refrig./Air Cond. Heat Pumps	Exchangeable orifices
TIH	3.1...28.4	+20...-45	Refrig./Air Cond. Heat Pumps	Hermetic, superheat adjustable, Optional with bleed hole
TX7	32...183 (R410A)	+20...-45	Air-Cond. Heat Pumps	Hermetic, superheat adjustable
T	1.9.. 301	+30...-45	Refrig./Air Cond. Heat Pumps	Exchangeable orifices, Power-assembly and flange
ZZ	1.7...24.7	-45...-120	Low Temperature Application	Exchangeable orifices, Power-assembly and flange
L	1.9...222	+30...-50	Liquid Injection Superheat Control	Exchangeable orifices, Power-assembly and flange
935	5.2...59.8	+30...-45	Liquid Injection Temperature Control	Exchangeable orifices, Power-assembly and flange

Thermo™ - Expansion Valves Series TI

Exchangeable Orifices

Features

- Laser-welded diaphragm / power element with large diameter for high reliability and maximum lifetime
- Constant superheat across wide application ranges
- Easy and precise superheat setting by internal fine threads
- Three styles of connections:
 - TILE: Stainless steel brazed fittings eliminate the need of wet rags during brazing
 - TIS(E): Copper brazed fittings (valve requires wet rag during brazing)
 - TI(E): Flare
- With capacities between 0.5kW and 19.4 kW (R448A) ideally suited for service work
- Internal or external equaliser
- Cleanable / exchangeable inlet strainer in orifice assembly
- Inlet brazing adapter
- Capillary tube length 1.5 m
- Max. allowable pressure PS: 45 bar
- Temperature range TS: -45...+75°C
- CE Marking acc. PED not required



Type Code

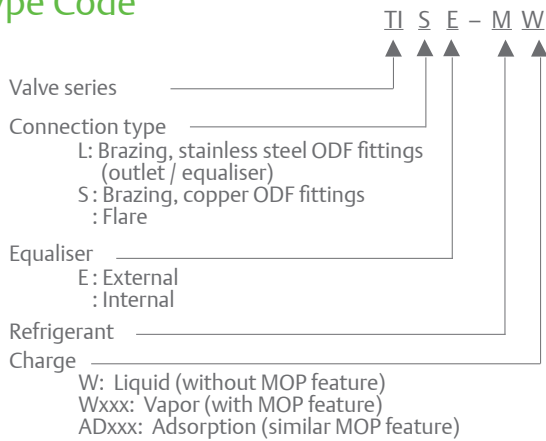

TILE



TIE

Selection Table for Orifice Assembly with Strainer for Inlet Connection

		Nominal Capacity (kW)							
Type		TIO-00X	TIO-000	TIO-001	TIO-002	TIO-003	TIO-004	TIO-005	TIO-006
Part No.		800 532	800 533	800 534	800 535	800 536	800 537	800 538	800 539
AL	R134a	0.3	0.8	1.9	3.1	5.0	8.3	10.1	11.7
	R22	0.5	1.3	3.2	5.3	8.5	13.9	16.9	19.5
	R404A/R507	0.4	1.0	2.3	3.9	6.2	10.1	12.3	14.2
	R407C	0.5	1.4	3.5	5.7	9.2	15	18.3	21.1
	R410A	0.6	1.5	3.7	6.2	9.9	16.2	19.7	22.8
	R448A	0.5	1.3	3.2	5.3	8.5	13.9	16.9	19.4
	R449A	0.5	1.3	3.1	5.2	8.3	13.5	16.5	19.0
	R513A/R450A	0.3	0.7	1.7	2.8	4.5	7.5	9.1	10.6
	R452A	0.4	1.0	2.4	4.0	6.4	10.5	12.8	14.8
AZL	R1234ze	0.2	0.6	1.5	2.4	3.9	6.5	7.9	9.1
	R455A	0.5	1.2	3.0	5.0	8.1	13.2	16.0	18.5
	R454C	0.4	1.1	2.6	4.3	7.0	11.4	13.8	16.0
	R1234yf	0.2	0.6	1.4	2.2	3.6	6.0	7.3	8.4
	R32	0.9	2.3	5.6	9.2	14.8	24.1	29.3	33.9

Note: Nominal conditions: Evaporating Temperature +4°C (dew point), Condensing Temperature +38°C (bubble point), Subcooling 1 K.
For selection of other operation conditions, please use the "Controls Navigator" selection tool.

Brazing Adapter for TILE and TIS(E)

Type	Part No.	Connection, ODF	
		(mm)	(inch)
TIA-M06	802 500	6.0	-
TIA-M10	802 501	10.0	-
TIA-014	802 502	-	1/4"
TIA-038	802 503	-	3/8"
Gasket Set	803 780	100 pieces	



TI Valve Bodies without Orifice and Nut

Refrigerant		Outlet/Equalizer Connection	Type	Part No.	Type	Part No.	MOP (°C)	Evaporating Temperature Range (°C)		
A1	A2L		External Equalizer		Internal Equalizer					
R404A/R507 R452A*		Brazing Stainless Steel Fittings *	TILE-SW (12 mm)	802465			-	-45 ... +20		
			TILE-SW (1/2")	802466			-	-45 ... +20		
		Brazing Copper Fittings **	TISE-SW (12 mm)	802462	TIS-SW (12 mm)	802461	-	-45 ... +20		
			TISE-SW (1/2")	802464	TIS-SW (1/2")	802463	-	-45 ... +20		
			TISE-SAD10 (1/2")	802479	TIS-SAD10 (1/2")	802478	+10	-45 ... 0		
			TISE-SW75 (12 mm)	802471			0	-45 ... -3		
			TISE-SW75 (1/2")	802472			0	-45 ... -3		
			TISE-SAD-20 (12 mm)	802474			-20	-45 ... -27		
		Flare Fittings	TISE-SAD-20 (1/2")	802475			-20	-45 ... -27		
			TIE-SW	802460	TI-SW	802459	-	-45 ... +20		
			TIE-SAD10	802477			+10	-45 ... 0		
			TIE-SW75	802470	TI-SW75	802469	0	-45 ... -3		
		R134a R450A*	R1234ze*	Brazing Stainless Steel Fittings *	TILE-MW (12 mm)	802451			-	-45 ... +20
					TILE-MW (1/2")	802452			-	-45 ... +20
				Brazing Copper Fittings **	TISE-MW (12 mm)	802448	TIS-MW (12 mm)	802447	-	-45 ... +20
					TISE-MW (1/2")	802450	TIS-MW (1/2")	802449	-	-45 ... +20
TISE-MW55 (12 mm)	802457						+14	-45 ... +11		
TISE-MW55 (1/2")	802458						+14	-45 ... +11		
Flare Fittings	TIE-MW			802446	TI-MW	802445	-	-45 ... +20		
	TIE-MW55			802456	TI-MW55	802455	+14	-45 ... +11		
R407C				Brazing Stainless Steel Fittings *	TILE-NW (12 mm)	802486			-	-45 ... +20
					TILE-NW (1/2")	802485			-	-45 ... +20
		Brazing Copper Fittings **	TISE-NW (12 mm)	802438	TIS-NW (12 mm)	802437	-	-45 ... +20		
			TISE-NW (1/2")	802440	TIS-NW (1/2")	802439	-	-45 ... +20		
		Flare Fittings	TIE-NW	802436	TI-NW	802435	-	-45...+20		
R410A	R32*	Brazing Stainless Steel Fittings *	TILE-ZW (12 mm)	802488			-	-35...+20		
			TILE-ZW (1/2")	802489			-	-35...+20		
			TILE-ZW175 (12 mm)	802490			+16.4	-35...+15		
			TILE-ZW175 (1/2")	802491			+16.4	-35...+15		
R448A / R449A		Brazing Stainless Steel Fittings *	TILE-BW (12 mm)	802418			-	-45...+20		
			TILE-BW (1/2")	802419			-	-45...+20		
		Brazing Copper Fittings **	TISE-BW (12 mm)	802416	TIS-BW(12 mm)	802414	-	-45...+20		
			TISE-BW (1/2")	802417	TIS-BW(1/2")	802415	-	-45...+20		
			TISE-BW30 (12 mm)	802494			-15	-45...-18		
			TISE-BW30 (1/2")	802495			-15	-45...-18		
		Flare Fittings	TIE-BW	802413	TI-BW	802412	-	-45...+20		

Note: *) TILE Brazing without wet rag

**) TISE Brazing with wet rag

***) Superheat readjustment required - see Operating Instruction

TI Valve Bodies without Orifice and Nut

Refrigerant		Outlet/Equalizer Connection	Type	Part No.	Type	Part No.	MOP (°C)	Evaporating Temperature Range (°C)
A1	A2L		External Equalizer		Internal Equalizer			
R513A		Brazing Stainless Steel Fittings**	TILE-CW (12 mm)	802166			-	-30...+20°C
			TILE-CW (1/2")	802167			-	-30...+20°C
		Brazing Copper Fittings***	TISE-CW (12 mm)	802168	TIS-CW (12 mm)	802170	-	-30...+20°C
			TISE-CW (1/2")	802169	TIS-CW (1/2")	802171	-	-30...+20°C
		Flare Fittings	TIE-CW	802172	TI-CW	802173	-	-30...+20°C
R454C		Brazing Stainless Steel Fittings**	TILE-LW (12 mm)	802150			-	-35...+20°C
			TILE-LW (1/2")	802151			-	-35...+20°C
		Brazing Copper Fittings***	TISE-LW (12 mm)	802152	TIS-LW (12 mm)	802154	-	-35...+20°C
			TISE-LW (1/2")	802153	TIS-LW (1/2")	802155	-	-35...+20°C
		Flare Fittings	TIE-LW	802156	TI-LW	802157	-	-35...+20°C
R455A		Brazing Stainless Steel Fittings**	TILE-KW (12 mm)	802158			-	-35...+20°C
			TILE-KW (1/2")	802159			-	-35...+20°C
		Brazing Copper Fittings***	TISE-KW (12 mm)	802160	TIS-KW (12 mm)	802162	-	-35...+20°C
			TISE-KW (1/2")	802161	TIS-KW (1/2")	802163	-	-35...+20°C
		Flare Fittings	TIE-KW	802164	TI-KW	802165	-	-35...+20°C
R1234yf		Brazing Stainless Steel Fittings**	TILE-FW (12 mm)	802174			-	-35...+20°C
			TILE-FW (1/2")	802175			-	-35...+20°C
		Brazing Copper Fittings***	TISE-FW (12 mm)	802176	TIS-FW (12 mm)	802178	-	-35...+20°C
			TISE-FW (1/2")	802177	TIS-FW (1/2")	802179	-	-35...+20°C
		Flare Fittings	TIE-FW	802180	TI-FW	802181	-	-35...+20°C

Note: *) TILE Brazing without wet rag

**) TISE Brazing with wet rag

**) Superheat readjustment required - see Operating Instruction

Connections

Body	Inlet Connection		Outlet	External Equalizer*
	Brazing with Adapter	Flare		
TI(E) Flare connections	-	5/8" - 18 UNF Flare suitable for 6 mm, 8 mm, 10 mm, 1/4", 5/16", 3/8" tubes	3/4" - 16 UNF Flare: for 12 mm, 1/2" tubes	7/16" - 20 UNF Flare: for 6 mm, 1/4" tubes
TIS(E) / TILE Braze connections	TIA - M06 (6 mm ODF) TIA - M10 (10 mm ODF)		12 mm ODF	6 mm ODF
	TIA - 014 (1/4" ODF) TIA - 038 (3/8" ODF)		1/2 ODF	1/4" ODF

Note: *) TIE, TISE and TILE

Thermo™ - Expansion Valves Series TIH

For OEM use, hermetic design

Features

- Compact size and hermetic design
- Up to 35 kW for R410A, 49 kW for R32
- Brazing and metric connections with straight through configuration
- Stainless steel power element resists corrosion
- Large diaphragm provides smoother and consistent valve control
- Internal or external equalizer
- External superheat adjustment
- Standard with integrated 100 mesh size strainer at inlet of valve
- Packaging with 20 pieces necked including bulb fastening accessories and single operating instruction

TIH



Options

- Single engineering sample for test purpose
- Special setting or bleed hole function on request: minimum order quantity 100 pieces per batch, type and order
- Valve without internal strainer on request: minimum order quantity 100 pieces per batch, type and order

Selection Table R32 / R410A / R452B / R454B

Nominal Capacity (kW)				with MOP		Connection		
R410A	R32 *	R452B *	R454B *	Type	Part No.	Inlet	Outlet	Equalizer
3.6	5.4	4.1	4.2	TIH-Z12m	802622M	6 mm	10 mm	internal
3.6	5.4	4.1	4.2	TIH-Z12	802636M	1/4"	3/8"	internal
6.0	9.0	6.9	6.9	TIH-Z13m	802623M	6 mm	10 mm	internal
6.0	9.0	6.9	6.9	TIH-Z13	802637M	1/4"	3/8"	internal
8.4	12.5	9.6	9.7	TIH-Z14m	802624M	10 mm	12 mm	internal
8.4	12.5	9.6	9.7	TIH-Z14	802638M	3/8"	1/2"	internal
3.6	5.4	4.1	4.2	TIH-Z32m	802625M	6 mm	10 mm	6 mm
3.6	5.4	4.1	4.2	TIH-Z32	802639M	1/4"	3/8"	1/4"
6.0	9.0	6.9	6.9	TIH-Z33m	802626M	6 mm	10 mm	6 mm
6.0	9.0	6.9	6.9	TIH-Z33	802640M	1/4"	3/8"	1/4"
8.4	12.5	9.6	9.7	TIH-Z34m	802627M	10 mm	12 mm	6 mm
8.4	12.5	9.6	9.7	TIH-Z34	802641M	3/8"	1/2"	1/4"
12.4	18.4	14.2	14.2	TIH-Z35m	802628M	10 mm	12 mm	6 mm
12.4	18.4	14.2	14.2	TIH-Z35	802642M	3/8"	1/2"	1/4"
14.6	21.8	16.7	16.8	TIH-Z36m	802629M	10 mm	12 mm	6 mm
14.6	21.8	16.7	16.8	TIH-Z36	802643M	3/8"	1/2"	1/4"
20.8	31.0	23.8	23.9	TIH-Z37m	802630M	12 mm	16 mm	6 mm
20.8	31.0	23.8	23.9	TIH-Z37	802644M	1/2"	5/8"	1/4"
23.2	34.6	26.6	26.7	TIH-Z38m	802631M	12 mm	16 mm	6 mm
23.2	34.6	26.6	26.7	TIH-Z38	802645M	1/2"	5/8"	1/4"
26.7	39.7	30.5	30.7	TIH-Z39m	802632M	12 mm	16 mm	6 mm
26.7	39.7	30.5	30.7	TIH-Z39	802646M	1/2"	5/8"	1/4"
33.2	49.4	38	38.2	TIH-Z3Am	802633M	12 mm	16 mm	6 mm
33.2	49.4	38	38.2	TIH-Z3A	802647M	1/2"	5/8"	1/4"

Note 1: Nominal conditions: Evaporating Temperature +4°C (dew point), Condensing Temperature +38°C (bubble point), Subcooling 1 K

Note 2: *) Superheat readjustment required - see Operating Instruction

Selection Table R134a / R450A

Capacity (kW)		without MOP		with MOP		Connection		
R134a	R450A*	Type	Part No.	Type	Part No.	Inlet	Outlet	Equalizer
2.4	2.1	TIH-M02m	802510M	TIH-M12m	802538M	6 mm	10 mm	internal
2.4	2.1	TIH-M02	802524M	TIH-M12	802552M	1/4"	3/8"	internal
4.0	3.5	TIH-M03m	802511M	TIH-M13m	802539M	6 mm	10 mm	internal
4.0	3.5	TIH-M03	802525M	TIH-M13	802553M	1/4"	3/8"	internal
5.6	4.9	TIH-M04m	802512M	TIH-M14m	802540M	10 mm	12 mm	internal
5.6	4.9	TIH-M04	802526M	TIH-M14	802554M	3/8"	1/2"	internal
2.4	2.1	TIH-M22m	802513M	TIH-M32m	802541M	6 mm	10 mm	6 mm
2.4	2.1	TIH-M22	802527M	TIH-M32	802555M	1/4"	3/8"	1/4"
4.0	3.5	TIH-M23m	802514M	TIH-M33m	802542M	6 mm	10 mm	6 mm
4.0	3.5	TIH-M23	802528M	TIH-M33	802556M	1/4"	3/8"	1/4"
5.6	4.9	TIH-M24m	802515M	TIH-M34m	802543M	10 mm	12 mm	6 mm
5.6	4.9	TIH-M24	802529M	TIH-M34	802557M	3/8"	1/2"	1/4"
8.2	7.2	TIH-M25m	802516M	TIH-M35m	802544M	10 mm	12 mm	6 mm
8.2	7.2	TIH-M25	802530M	TIH-M35	802558M	3/8"	1/2"	1/4"
9.7	8.5	TIH-M26m	802517M	TIH-M36m	802545M	10 mm	12 mm	6 mm
9.7	8.5	TIH-M26	802531M	TIH-M36	802559M	3/8"	1/2"	1/4"
13.8	12.2	TIH-M27m	802518M	TIH-M37m	802546M	12 mm	16 mm	6 mm
13.8	12.2	TIH-M27	802532M	TIH-M37	802560M	1/2"	5/8"	1/4"
15.4	13.6	TIH-M28m	802519M	TIH-M38m	802547M	12 mm	16 mm	6 mm
15.4	13.6	TIH-M28	802533M	TIH-M38	802561M	1/2"	5/8"	1/4"
17.7	15.6	TIH-M39m	802520M	TIH-M39m	802548M	12 mm	16 mm	6 mm
17.7	15.6	TIH-M29	802534M	TIH-M39	802562M	1/2"	5/8"	1/4"
22.0	19.4	TIH-M3Am	802521M	TIH-M3Am	802549M	12 mm	16 mm	6 mm
22.0	19.4	TIH-M2A	802535M	TIH-M3A	802563M	1/2"	5/8"	1/4"

Note 1: Nominal conditions: Evaporating Temperature +4°C (dew point), Condensing Temperature +38°C (bubble point), Subcooling 1 K

Note 2: *) Superheat readjustment required - see Operating Instruction

Selection Table R407C / R454C

Capacity (kW)		without MOP		with MOP		Connection		
R407C	R454C*	Type	Part No.	Type	Part No.	Inlet	Outlet	Equalizer
3.3	2.5	TIH-N02m	802566M	TIH-N12m	802594M	6 mm	10 mm	internal
3.3	2.5	TIH-N02	802580M	TIH-N12	802608M	1/4"	3/8"	internal
5.4	4.2	TIH-N03m	802567M	TIH-N13m	802595M	6 mm	10 mm	internal
5.4	4.2	TIH-N03	802581M	TIH-N13	802609M	1/4"	3/8"	internal
7.6	5.9	TIH-N04m	802568M	TIH-N14m	802596M	10 mm	12 mm	internal
7.6	5.9	TIH-N04	802582M	TIH-N14	802610M	3/8"	1/2"	internal
3.3	2.5	TIH-N22m	802569M	TIH-N32m	802597M	6 mm	10 mm	6 mm
3.3	2.5	TIH-N22	802583M	TIH-N32	802611M	1/4"	3/8"	1/4"
5.4	4.2	TIH-N23m	802570M	TIH-N33m	802598M	6 mm	10 mm	6 mm
5.4	4.2	TIH-N23	802584M	TIH-N33	802612M	1/4"	3/8"	1/4"
7.6	5.9	TIH-N24m	802571M	TIH-N34m	802599M	10 mm	12 mm	6 mm
7.6	5.9	TIH-N24	802585M	TIH-N34	802613M	3/8"	1/2"	1/4"
11.2	8.7	TIH-N25m	802572M	TIH-N35m	802600M	10 mm	12 mm	6 mm
11.2	8.7	TIH-N25	802586M	TIH-N35	802614M	3/8"	1/2"	1/4"
13.2	10.3	TIH-N26m	802573M	TIH-N36m	802601M	10 mm	12 mm	6 mm
13.2	10.3	TIH-N26	802587M	TIH-N36	802615M	3/8"	1/2"	1/4"
18.8	14.6	TIH-N27m	802574M	TIH-N37m	802602M	12 mm	16 mm	6 mm
18.8	14.6	TIH-N27	802588M	TIH-N37	802616M	1/2"	5/8"	1/4"
21	16.3	TIH-N28m	802575M	TIH-N38m	802603M	12 mm	16 mm	6 mm
21	16.3	TIH-N28	802589M	TIH-N38	802617M	1/2"	5/8"	1/4"
24.1	18.7	TIH-N29m	802576M	TIH-N39m	802604M	12 mm	16 mm	6 mm
24.1	18.7	TIH-N29	802590M	TIH-N39	802618M	1/2"	5/8"	1/4"
30	23.3	TIH-N2Am	802577M	TIH-N3Am	802605M	12 mm	16 mm	6 mm
30	23.3	TIH-N2A	802591M	TIH-N3A	802619M	1/2"	5/8"	1/4"

Note 1: Nominal conditions: Evaporating Temperature +4°C (dew point), Condensing Temperature +38°C (bubble point), Subcooling 1 K

Note 2: *) Superheat readjustment required - see Operating Instruction

Selection Table R448A / R449A / R454A / R455A

Capacity (kW)				without MOP		Connection		
R448A	R449A	R454A*	R455A*	Type	Part No.	Inlet	Outlet	Equalizer
3.1	3	3.0	2.9	TIH-B02m	802706M	6 mm	10 mm	internal
3.1	3	3.0	2.9	TIH-B02	802720M	1/4"	3/8"	internal
5.1	5	5.1	4.9	TIH-B03m	802707M	6 mm	10 mm	internal
5.1	5	5.1	4.9	TIH-B03	802721M	1/4"	3/8"	internal
7.2	7	7.1	6.8	TIH-B04m	802708M	10 mm	12 mm	internal
7.2	7	7.1	6.8	TIH-B04	802722M	3/8"	1/2"	internal
3.1	3	3.0	2.9	TIH-B22m	802709M	6 mm	10 mm	6 mm
3.1	3	3.0	2.9	TIH-B22	802723M	1/4"	3/8"	1/4"
5.1	5	5.1	4.9	TIH-B23m	802710M	6 mm	10 mm	6 mm
5.1	5	5.1	4.9	TIH-B23	802724M	1/4"	3/8"	1/4"
7.2	7	7.1	6.8	TIH-B24m	802711M	10 mm	12 mm	6 mm
7.2	7	7.1	6.8	TIH-B24	802725M	3/8"	1/2"	1/4"
10.6	10.3	10.4	10.1	TIH-B25m	802712M	10 mm	12 mm	6 mm
10.6	10.3	10.4	10.1	TIH-B25	802726M	3/8"	1/2"	1/4"
12.5	12.2	12.3	11.9	TIH-B26 mm	802713M	10 mm	12 mm	6 mm
12.5	12.2	12.3	11.9	TIH-B26	802727M	3/8"	1/2"	1/4"
17.8	17.4	17.5	16.9	TIH-B27m	802714M	12 mm	16 mm	6 mm
17.8	17.4	17.5	16.9	TIH-B27	802728M	1/2"	5/8"	1/4"
19.9	19.4	19.6	18.9	TIH-B28m	802715M	12 mm	16 mm	6 mm
19.9	19.4	19.6	18.9	TIH-B28	802729M	1/2"	5/8"	1/4"
22.8	22.3	22.5	21.6	TIH-B29m	802716M	12 mm	16 mm	6 mm
22.8	22.3	22.5	21.6	TIH-B29	802730M	1/2"	5/8"	1/4"
28.4	27.7	28.0	27.0	TIH-B2Am	802717M	12 mm	16 mm	6 mm
28.4	27.7	28.0	27.0	TIH-B2A	802731M	1/2"	5/8"	1/4"

Note 1: Nominal conditions: Evaporating Temperature +4°C (dew point), Condensing Temperature +38°C (bubble point), Subcooling 1 K

Note 2: *) Superheat readjustment required - see Operating Instruction

Selection Table R513A / R1234yf

Capacity (kW)		without MOP		with MOP		Connection		
R513A	R1234yf*	Type	Part No.	Type	Part No.	Inlet	Outlet	Equalizer
2.2	1.7	TIH-C02m	808400M	TIH-C12m	808428M	6 mm	10 mm	internal
2.2	1.7	TIH-C02	808414M	TIH-C12	808442M	1/4"	3/8"	internal
3.6	2.9	TIH-C03m	808401M	TIH-C13m	808429M	6 mm	10 mm	internal
3.6	2.9	TIH-C03	808415M	TIH-C13	808443M	1/4"	3/8"	internal
5.0	4.0	TIH-C04m	808402M	TIH-C14m	808430M	10 mm	12 mm	internal
5.0	4.0	TIH-C04	808416M	TIH-C14	808444M	3/8"	1/2"	internal
2.2	1.7	TIH-C22m	808403M	TIH-C32m	808431M	6 mm	10 mm	6 mm
2.2	1.7	TIH-C22	808417M	TIH-C32	808445M	1/4"	3/8"	1/4"
3.6	2.9	TIH-C23m	808404M	TIH-C33m	808432M	6 mm	10 mm	6 mm
3.6	2.9	TIH-C23	808418M	TIH-C33	808446M	1/4"	3/8"	1/4"
5.0	4.0	TIH-C24m	808405M	TIH-C34m	808433M	10 mm	12 mm	6 mm
5.0	4.0	TIH-C24	808419M	TIH-C34	808447M	3/8"	1/2"	1/4"
7.4	5.9	TIH-C25m	808406M	TIH-C35m	808434M	10 mm	12 mm	6 mm
7.4	5.9	TIH-C25	808420M	TIH-C35	808448M	3/8"	1/2"	1/4"
8.8	7.0	TIH-C26m	808407M	TIH-C36m	808435M	10 mm	12 mm	6 mm
8.8	7.0	TIH-C26	808421M	TIH-C36	808449M	3/8"	1/2"	1/4"
12.5	10.0	TIH-C27m	808408M	TIH-C37m	808436M	12 mm	16 mm	6 mm
12.5	10.0	TIH-C27	808422M	TIH-C37	808450M	1/2"	5/8"	1/4"
13.9	11.1	TIH-C28m	808409M	TIH-C38m	808437M	12 mm	16 mm	6 mm
13.9	11.1	TIH-C28	808423M	TIH-C38	808451M	1/2"	5/8"	1/4"
16.0	12.7	TIH-C29m	808410M	TIH-C39m	808438M	12 mm	16 mm	6 mm
16.0	12.7	TIH-C29	808424M	TIH-C39	808452M	1/2"	5/8"	1/4"
19.9	15.9	TIH-C2Am	808411M	TIH-C3Am	808439M	12 mm	16 mm	6 mm
19.9	15.9	TIH-C2A	808425M	TIH-C3A	808453M	1/2"	5/8"	1/4"

Note 1: Nominal conditions: Evaporating Temperature +4°C (dew point), Condensing Temperature +38°C (bubble point), Subcooling 1 K

Note 2: *) Superheat readjustment required - see Operating Instruction

Standard MOPs

Refrigerant	Standard MOP	Corresponding Ttemperature	Recommended Max. Design Evaporating Temperature
R134a	3.8 bar	+16°C	+12°C
R513A	3.8 bar	+14°C	+10°C
R407C	6.9 bar	+14.5°C	+12.5°C
R410A	13.4 bar	+20°C	+18°C
R32	13.4 bar	+20°C	+18°C
R452B	13.4 bar	+22°C	+20°C
R454B	13.4 bar	+22°C	+20°C

Charge	MOP	Refrigerant	Maximum Bulb Temperature
TIH-M0../M2..	-	R134a	+100°C
TIH-N0../N2..	-	R407C	+80°C
TIH-B0../B2..	-	R448A, R449A	+80°C
TIH-C0../C2..	-	R513A	+100°C
TIH-M1../M3..	3.8 bar	R134a	+120°C
TIH-C1../C3..	3.8 bar	R513A	+120°C
TIH-N1../N3..	6.9 bar	R407C	+120°C
TIH-Z1../Z3..	12.1 bar	R410A	+120°C

Thermo™ -Expansion Valves Series TX7

TX7 series of Thermo-Expansion Valves are designed predominantly for AC, heat pumps, close control and industrial process cooling applications. The TX7 is ideal for those applications requiring hermetic / compact size combined with stable and accurate control over wide load and evaporating temperature ranges.

Features

- Monoblock, hermetic valve with brazing connections
- 7 sizes up to 180 kW (R410A)
- Maximum allowable pressure: PS 46 bar
- Factory test pressure PT: 50.6 bar
- Bi-Flow application
 - Balanced port in normal and reverse flow directions eliminates disturbance forces resulting from condensing pressure
 - Optimum static superheat in normal and reverse flow
 - Capacities performance in normal and reverse flow correlates to capacity of heat pumps in cooling and heating mode
- Power Element with 65 mm diameter enables low partial load (20-25%) performance at stable superheat
- Applicable in systems with digital scroll, step less screw compressors and variable speed compressors
- Floating superheat in reverse flow (heating mode) supports evaporator efficiency during low ambient operating conditions in air cooled reversible chillers
- Laser welded stainless steel power element with a special diaphragm profile provides life expectancy against high pressure during reversed flow via external equalizer.
- Single diaphragm with negligible hysteresis withstands against higher pressure
- Fine tuning by external superheat adjusting mechanism
- Special factory setting upon request. Minimum order quantity 60 pieces



TX7-Z13

Selection Table R410A / R32 / R452B / R454B

Nominal Capacity (kW)								With MOP		Connection	
R410A		R32*		R452B*		R454B*		Type	Part No.	Inlet x Outlet	Equalizer
Normal Flow	Reverse Flow	Normal Flow	Reverse Flow	Normal Flow	Reverse Flow	Normal Flow	Reverse Flow				
32.1	31.7	47.7	46.9	36.7	36.3	36.9	36.5	TX7-Z13m	806811	12 mm x 16 mm	6 mm
32.1	31.7	47.7	46.9	36.7	36.3	36.9	36.5	TX7-Z13	806810	1/2" x 5/8"	1/4"
39.9	39.1	59.3	57.8	45.6	44.7	45.8	44.9	TX7-Z14m	806813	16 mm x 22 mm	6 mm
39.9	39.1	59.3	57.8	45.6	44.7	45.8	44.9	TX7-Z14	806812	5/8" x 7/8"	1/4"
48.9	47.4	72.7	70.1	55.9	54.2	56.1	54.4	TX7-Z15m	806815	16 mm x 22 mm	6 mm
48.9	47.4	72.7	70.1	55.9	54.2	56.1	54.4	TX7-Z15	806814	5/8" x 7/8"	1/4"
80.7	67.7	120	100.2	92.2	77.4	92.7	77.9	TX7-Z16m	806817	22 mm x 28 mm	6 mm
80.7	67.7	120	100.2	92.2	77.4	92.7	77.9	TX7-Z16	806816	7/8" x 1-1/8"	1/4"
99.4	81.5	147.9	120.5	113.7	93.2	114.3	93.7	TX7-Z17m	806819	22 mm x 28 mm	6 mm
99.4	81.5	147.9	120.5	113.7	93.2	114.3	93.7	TX7-Z17	806818	7/8" x 1-1/8"	1/4"
130.9	113.9	194.7	168.4	149.7	130.2	150.4	130.8	TX7-Z18m	806821	22 mm x 28 mm	6 mm
130.9	113.9	194.7	168.4	149.7	130.2	150.4	130.8	TX7-Z18	806820	7/8" x 1-1/8"	1/4"
183.4	165.1	272.9	244.1	209.8	188.8	210.8	189.7	TX7-Z19m	806823	22 mm x 28 mm	6 mm
183.4	165.1	272.9	244.1	209.8	188.8	210.8	189.7	TX7-Z19	806822	7/8" x 1-1/8"	1/4"

Note 1: *) Superheat readjustment required - see Operating Instruction

Note 2: Nominal conditions: Evaporating Temperature +4°C (dew point), Condensing Temperature +38°C (bubble point), Subcooling 1 K

Selection Table R134a / R450A / R513A / R1234yf

Nominal Capacity (kW)								with MOP		without MOP		Connection	
R134a		R450A*		R513A*		R1234yf*							
Normal Flow	Reverse Flow	Normal Flow	Reverse Flow	Normal Flow	Reverse Flow	Normal Flow	Reverse Flow	Type	Part No.	Type	Part No.	Inlet x Outlet	Equalizer
18.1	17.9	15.9	15.8	16.3	16.1	13.0	12.9	TX7-M13m	806839	TX7-M03m	806825	12 mm x 16 mm	6 mm
18.1	17.9	15.9	15.8	16.3	16.1	13.0	12.9	TX7-M13	806838	TX7-M03	806824	1/2" x 5/8"	1/4"
22.5	22	19.8	19.4	20.3	19.9	16.2	15.9	TX7-M14m	806841	TX7-M04m	806827	16 mm x 22 mm	6 mm
22.5	22	19.8	19.4	20.3	19.9	16.2	15.9	TX7-M14	806840	TX7-M04	806826	5/8" x 7/8"	1/4"
27.5	26.7	24.3	23.5	24.8	24.1	19.8	19.2	TX7-M15m	806843	TX7-M05m	806829	16 mm x 22 mm	6 mm
27.5	26.7	24.3	23.5	24.8	24.1	19.8	19.2	TX7-M15	806842	TX7-M05	806828	5/8" x 7/8"	1/4"
45.4	38.2	40.1	33.6	41.0	34.4	32.8	27.5	TX7-M16m	806845	TX7-M06m	806831	22 mm x 28 mm	6 mm
45.4	38.2	40.1	33.6	41.0	34.4	32.8	27.5	TX7-M16	806844	TX7-M06	806830	7/8" x 1-1/8"	1/4"
56	45.9	49.4	40.5	50.6	41.5	40.4	33.1	TX7-M17m	806847	TX7-M07m	806833	22 mm x 28 mm	6 mm
56	45.9	49.4	40.5	50.6	41.5	40.4	33.1	TX7-M17	806846	TX7-M07	806832	7/8" x 1-1/8"	1/4"
73.7	64.1	65.0	56.6	66.6	57.9	53.2	46.3	TX7-M18m	806849	TX7-M08m	806835	22 mm x 28 mm	6 mm
73.7	64.1	65.0	56.6	66.6	57.9	53.2	46.3	TX7-M18	806848	TX7-M08	806834	7/8" x 1-1/8"	1/4"
103.3	93	91.1	82.0	93.3	83.9	74.5	67.0	TX7-M19m	806851	TX7-M09m	806837	22 mm x 28 mm	6 mm
103.3	93	91.1	82.0	93.3	83.9	74.5	67.0	TX7-M19	806850	TX7-M09	806836	7/8" x 1-1/8"	1/4"

Selection Table R407C / R454C

Nominal Capacity (kW)				with MOP		without MOP		Connection	
R407C		R454C*							
Normal Flow	Reverse Flow	Normal Flow	Reverse Flow	Type	Part No.	Type	Part No.	Inlet x Outlet	Equalizer
28.9	28.6	22.5	22.3	TX7-N13m	806868	TX7-N03m	806853	12 mm x 16 mm	6 mm
28.9	28.6	22.5	22.3	TX7-N13	806867	TX7-N03	806852	1/2" x 5/8"	1/4"
36	35.2	27.9	27.4	TX7-N14m	806870	TX7-N04m	806855	16 mm x 22 mm	6 mm
36	35.2	27.9	27.4	TX7-N14	806869	TX7-N04	806854	5/8" x 7/8"	1/4"
44.1	42.7	34.2	33.2	TX7-N15m	806872	TX7-N05m	806857	16 mm x 22 mm	6 mm
44.1	42.7	34.2	33.2	TX7-N15	806871	TX7-N05	806856	5/8" x 7/8"	1/4"
72.7	61.1	56.5	47.5	TX7-N16m	806874	TX7-N06m	806859	22 mm x 28 mm	6 mm
72.7	61.1	56.5	47.5	TX7-N16	806873	TX7-N06	806858	7/8" x 1-1/8"	1/4"
89.7	73.5	69.7	57.1	TX7-N17m	806876	TX7-N07m	806861	22 mm x 28 mm	6 mm
89.7	73.5	69.7	57.1	TX7-N17	806875	TX7-N07	806860	7/8" x 1-1/8"	1/4"
118.1	102.7	91.8	79.8	TX7-N18m	806878	TX7-N08m	806863	22 mm x 28 mm	6 mm
118.1	102.7	91.8	79.8	TX7-N18	806877	TX7-N08	806862	7/8" x 1-1/8"	1/4"
165.4	148.9	128.6	115.7	TX7-N19m	806880	TX7-N09m	806865	22 mm x 28 mm	6 mm
165.4	148.9	128.6	115.7	TX7-N19	806879	TX7-N09	806864	7/8" x 1-1/8"	1/4"

Note 1: *) Superheat readjustment required - see Operating Instruction

Note 2: Nominal conditions: Evaporating Temperature +4°C (dew point), Condensing Temperature +38°C (bubble point), Subcooling 1 K

Charge	Refrigerant	Recommended Evaporating Temperature Range	Maximum Bulb Temperature
M0	R134a, R450A, R513A, R1234yf	-25...+30°C	88°C
N0	R407C, R454C	-25...+20°C	71°C
M1 MOP 3.8 bar	R134a, R450A, R513A, R1234yf	-25...+10°C	120°C
N1 MOP 6.9 bar	R407C, R454C	-25...+14°C	120°C
Z1 MOP 12.1 bar	R410A/ R32, R452B, R454B	-25...+14°C	120°C

Thermo™ -Expansion Valve Series T

Exchangeable Power Assemblies and Orifices

Features

- Modular design for economical logistics and easy assembly and servicing
- Very good stability due to large diaphragm diameter
- Constant superheat across a wide application range
- Superior partial load performance due to double seat orifice design (TJRE, TERE, TIRE & THRE)
- Bi-flow capability for applications in heat pumps
- Capillary tube length 1.5 m (TCLE, TJRE) and 3m (TERE, TIRE & THRE)
- Max. allowable pressure PS:
 - 46 bar with XB power assembly
 - 31 bar with XC power assembly
- Medium Temperature range TS: -45...+75°C
- Flanges: brazing ODF/ODM connection

TCLE



Type Code Valve

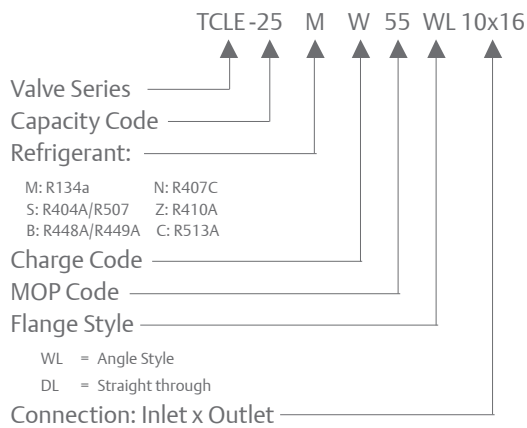

Type Code Power Element

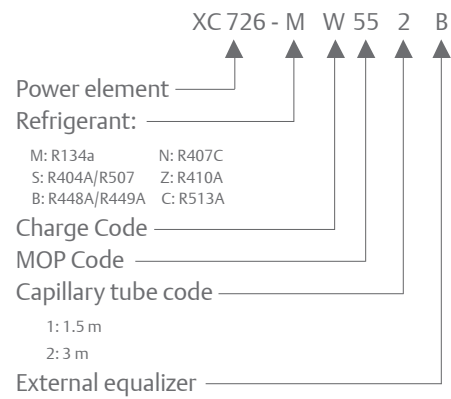

Nominal Capacities for Orifices

Valve Series	Type	Nominal Capacity (kW)					Type	Nominal Capacity (kW)		Orifice Type	Power Element Type
		R134a	R513A*	R450A*	R1234yf*	R1234ze*		R404A / R507	R452A*		
TCLE-	25MW	1.5	1.3	1.3	1.1	1.1	25SW	1.3	1.4	X22440-B1B	XB1019...1B
	75MW	2.9	2.6	2.5	2.1	2.2	75SW	2.6	2.8	X22440-B2B	
	150MW	6.1	5.5	5.4	4.4	4.8	150SW	5.6	6.0	X22440-B3B	
	200MW	9.3	8.3	8.1	6.6	7.2	200SW	8.4	9.0	X22440-B3,5B	
	250MW	13.5	12.1	11.8	9.6	10.5	250SW	12.2	13.1	X22440-B4B	
	350MW	17.3	15.5	15.1	12.4	13.4	400SW	15.7	16.8	X22440-B5B	
	550MW	23.6	21.2	20.7	17.0	18.4	600SW	21.5	23.0	X22440-B6B	
	750MW	32	28.7	28	22.9	24.8	850SW	29	31.1	X22440-B7B	
	900MW	37.2	33.4	32.6	26.7	28.9	1000SW	33.8	36.2	X22440-B8B	
TJRE-	11MW	45	40.5	39.6	32.3	35.1	12SW	40	43.9	X11873-B4B	XC726...2B
	13MW	57	51.7	50.5	41.3	44.7	14SW	51	56.0	X11873-B5B	
TERE-	16MW	71	63.5	62.1	50.7	55	18SW	63	68.9	X9117-B6B	
	19MW	81	72.6	70.9	58.0	62.9	20SW	72	78.7	X9117-B7B	
	25MW	112	99.8	97.5	79.7	86.4	27SW	99	108.3	X9117-B8B	
	31MW	135	121.5	118.7	97.0	105.2	34SW	120	131.7	X9117-B9B	
TIRE-	45MW	174	155.7	152.1	124.3	134.8	47SW	154	168.8	X9166-B10B	
THRE-	55MW	197	176.6	172.5	141.1	152.9	61SW	174	191.5	X9144-B11B	
	68MW	236	210.8	205.9	168.4	182.5	77SW	209	228.6	X9144-B13B	

Valve Series	Type	Nominal Capacity (kW)			Type	Nominal Capacity (kW)		Type	Nominal Capacity (kW)		Orifice Type	Power Element Type
		R448A	R449A	R454A*		R407C	R454C		R410A	R32		
TCLE-	55BW	1.9	1.9	1.8	50NW	2.1	1.6	50ZW	2.2	3.3	X22440-B1B	XB1019...1B
	100BW	3.7	3.6	3.5	100NW	4	3.0	100ZW	4.3	6.4	X22440-B2B	
	250BW	7.9	7.8	7.5	200NW	8.5	6.5	250ZW	9.2	13.7	X22440-B3B	
	350BW	11.9	11.7	11.3	300NW	12.9	9.7	400ZW	13.9	20.7	X22440-B3,5B	
	500BW	17.3	17.0	16.4	400NW	18.7	14.2	600ZW	20.2	30.0	X22440-B4B	
	650BW	22.1	21.8	21.0	550NW	24	18.2	750ZW	25.9	38.5	X22440-B5B	
	850BW	30.3	29.9	28.8	750NW	32.9	24.9	1000ZW	35.5	52.8	X22440-B6B	
	1150BW	41	40.4	38.9	1000NW	44.4	33.6	1400ZW	48	71.4	X22440-B7B	
	1350BW	47.7	47.0	45.3	1150NW	51.7	39.1	1600ZW	55.8	83.0	X22440-B8B	
TJRE-	17BW	57.8	57.0	54.9	14NW	62	47.4	19ZW	67.7	100.7	X11873-B4B	XC726...2B
	21BW	73.8	72.8	70.1	17NW	80	60.5	25ZW	86.4	128.5	X11873-B5B	
TERE-	26BW	90.7	89.5	86.2	21NW	99	74.4	-	-	-	X9117-B6B	
	30BW	103.7	102.3	98.5	25NW	112	85.1	-	-	-	X9117-B7B	
	41BW	142.6	140.6	135.4	33NW	155	117.0	-	-	-	X9117-B8B	
	50BW	173.5	171.1	164.8	42NW	188	142.3	-	-	-	X9117-B9B	
TIRE-	64BW	222.4	219.3	211.2	52NW	241	182.4	-	-	-	X9166-B10B	
THRE-	72BW	252.3	248.8	239.6	71NW	273	207.0	-	-	-	X9144-B11B	
	86BW	301.1	297.0	286.0	94NW	327	247.0	-	-	-	X9144-B13B	

Note 1: Nominal conditions: Evaporating Temperature +4°C (dew point), Condensing Temperature +38°C (bubble point), Subcooling 1 K

Note 2: *) Superheat readjustment required - see Operating Instruction

Note 3: For selection of other operation conditions, please use the "Controls Navigator" selection tool.

Selection Table Power Element and Recommended Flanges

Valve Series	Orifice Type	Angle Style Type	Straight Through Type	Connection (inlet x Outlet)		Power Element Type
				Metric	Imperial	
TCLE	X22440-B1B / B2B/ B3B / B3.5B / B4B	C501-5	9761-3	-	3/8"x5/8" ODF	XB1019...2B
		C501-5mm	9761-3mm	10x16 mm ODF	-	
	X22440-B5B / B6B	C501-7	9761-4		1/2"x5/8" ODF	
		C501-7mm	9761-4mm	12x16 mm ODF	-	
	X22440-B7B / B8B	-	6346-17	16x22 mm ODF	5/8"x7/8" ODF	
		A576	-	-	5/8"x7/8" ODF 7/8"x1-1/8" ODM	
A576-mm		-	16x22 mm ODF 22x28 mm ODM	-		
TJRE	X11873-B4B / B5B	10331	10332	22x22 mm ODF	7/8"x7/8" ODF 1-1/8"x1-1/8" ODM	
TERE	X9117-B6B / B7B / B8B / B9B	9153 9153-mm	9152 9152-mm	22x22 mm ODF 22x28 mm ODM	7/8"x7/8" ODF 1-1/8"x1-1/8" ODM	XC726...2B
TIRE						
THRE	X9144-B11B / B13B	9149	9148	22x22 mm ODF	7/8"x7/8" ODF 1-1/8"x1-1/8" ODM	

MOP Charges T-Series

MOP		Evaporating Temperature Range				
Code	bar	R134a MW	R404A/ R507 SW	R407C NW	R410A ZW	R448A/ R449A BW
15	1.0	-45... -16°C				
30	2.1					-45...-18°C
35	2.4	-45...0°C				
40	2.8		-45...-18°C			
55	3.8	-45...+11°C	-45...-10°C			
75	5.2		-45...-2°C			
80	5.5		-45...0°C			
100	6.9			-45...+14°C		
175	12.1				-45...+16°C	

Accessories and Spare Parts

Description	Type	Part No.
Service Tool for T, ZZ, L and 935 Series valves	X 99999	800005
Gasket sets for T, ZZ, L and 935 Series valves	X 13455-1	027579
Steel Screws for flange types: C501, 9761, 6346, A576	Screw ST 32	803573
Steel Screws for flange types: 9148, 9149, 9152, 9153, 10331, 10332	Screw ST 48	803574
Bulb clamp for XB1019	XA 1728-4	803260
Bulb clamp for XC726	XA 1728-5	803261

Thermo™ - Expansion Valve Series ZZ

for Low Evaporating Temperatures Between -45 and -100°C

Features

- Modular design for economical logistics and easy assembly and servicing
- Very good stability due to large diaphragm diameter
- High-quality materials and processes for high reliability and long lifetime
- To withstand stress at extremely low temperatures, ZZ-Series valves feature bronze bolts.
- Max. allowable pressure PS:
- 31 bar with XC power assembly



Type Code Valve

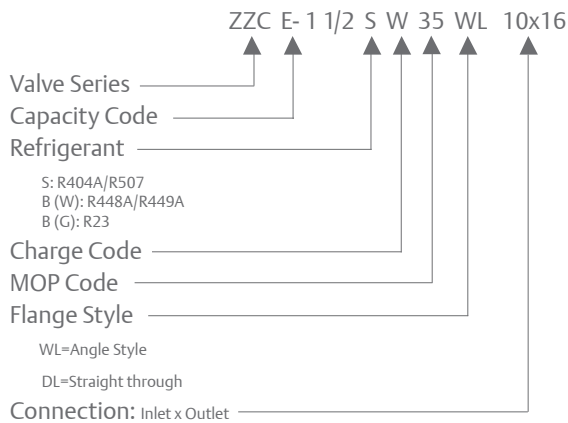

Type Code Power Element

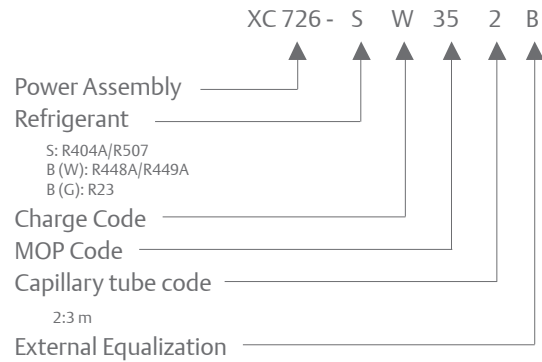

Selection Table

Valve Series	Type	Nominal Capacity (kW)		Type	Nominal Capacity (kW)			Orifice	Power Assembly		
		R23	Type		R404A / R507	R452A	R448A / R449A			R454A	R455A
ZZCE	2BG	1.9	2/4SW	1.2	1.3	1BW	1.7	1.7	1.6	X10-B01	XC726...2B
	6BG	4	1-1/2SW	2.6	2.8	2BW	3.7	3.7	3.4	X10-B02	
	8BG	6.8	2-1/2SW	4.4	4.6	3BW	6.2	6.2	5.7	X10-B03	
	12BG	10.8	3-1/2SW	7	7.4	5BW	9.8	9.8	9.1	X10-B04	
	17BG	16.3	5SW	10.6	11.1	6BW	14.8	14.8	13.7	X10-B05	
	25BG	21.7	8SW	14.1	14.8	10BW	19.8	19.8	18.2	X10-B06	
	31BG	27.1	9SW	17.6	18.5	12BW	24.7	24.7	22.8	X10-B07	

Note 1: Nominal conditions:

R23: Evaporating Temperature -60°C, Condensing Temperature -25°C, Subcooling 1 K

Other refrigerants: Evaporating Temperature -40°C (dew point), Condensing Temperature 25°C (bubble point), Subcooling 1 K

Note 2: Attention - To withstand stress at extremely low temperatures, ZZ-Series valves feature bronze bolts. Please order separately Screw BZ 32 Part No. 803575

Selection Table Power Element and Recommended Flanges

Valve Series	Orifice type	Connection Standard Flange, Angle Style		Connection (inlet x outlet)		Power Element Type
		Type	Type	Metric	Imperial	
ZZCE	X 10-B01/ B02/ B03	C501-5mm		10 X 16 mm ODF		XC726 ... 2B
			C501-5		3/8" X 5/8 ODF	
	X 10-B04/ B05	C501-7 mm		12x16 mm ODF		
			C501-7		1/2" x 5/8" ODF -	
	X 10-B04/ B05	A 576 mm		16x22 mm ODF		
			A 576	22x28 mm ODM	5/8" x 7/8" ODF	

MOP Charges ZZ-Series

MOP Code	MOP		Evaporating Temperature Range		
	bar	Tmax	R23	R404A/R507/R452A	R448A/ R449A/R545A/R455A
20	1.4	-66°C	-100 ... -71°C		
35	2.1	-14°C			-75 ... -18°C
40	2.8	-14°C		-75 ... -18°C	
55	3.8	-7°C		-75 ... -10°C	
60	4.1	-48°C	-100 ... -51°C		
125	8.6	-32°C	-100 ... -35°C		

Accessories and Spare Parts

Description	Type	Part No.
Service Tool for T, ZZ, L and 935 Series valves	X 99999	800005
Gasket sets for T, ZZ, L and 935 Series valves	X 13455-1	027579
Bronze screw for Flange types: C500, C501, 9761, X6346, X6669, A576	Screw BZ 32	803575
Bulb clamp for XC726	XA 1728-5	803261

Thermo™ -Expansion Valves L-Series

Exchangeable Power Assemblies and Orifices

Features

- Applications for series L valves include superheat control (desuperheating of suction gas i.e., in hotgas bypass systems and interstage cooling in multiple stage compressors)
- Modular design for economical logistics and easy assembly and servicing
- Very good stability is attained because of the large forces generated by the large diaphragm diameter
- High-quality materials and processes for high reliability and long lifetime
- Superior partial load performance due to seat orifice design (LJRE, LERE & LIRE)
- Max. allowable pressure PS
 - 46 bar with XB power assembly
 - 31 bar with XC power assembly.
- Medium Temperature Range TS: -45...+65°C



LCLE

Type Code Valve

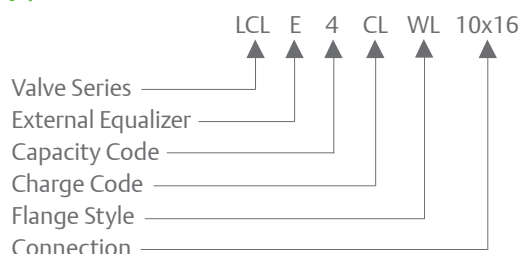

Type Code Power Assembly

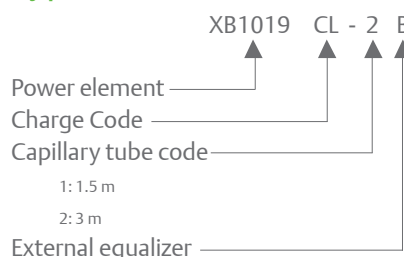

Nominal Capacities for Cages

Valve Series	Capacity Code *	Nominal Capacity Q _n (kW)														Orifice Type	Power Assembly Type
		R134a	R404A R507	R407C	R450A	R513A	R448A	R449A	R410A	R32	R454A	R454C	R1234yf	R1234ze	R455A		
LCLE	1 *	1.5	1.3	2.1	1.3	1.3	1.9	1.9	2.2	3.3	1.9	1.6	1.1	1.1	1.8	X 22440-B1B	XB1019...2B
	2 *	2.9	2.6	4	2.5	2.6	3.7	3.6	4.3	6.4	3.6	3.0	2.1	2.2	3.5	X 22440-B2B	
	3 *	6.1	5.6	8.5	5.4	5.5	7.9	7.7	9.2	13.7	7.8	6.5	4.4	4.8	7.5	X 22440-B3B	
	3.5 *	9.3	8.4	12.9	8.1	8.3	11.9	11.6	13.9	20.7	11.7	9.7	6.6	7.2	11.3	X 22440-B3.5B	
	4 *	13.5	12.2	18.7	11.8	12.1	17.3	16.9	20.2	30.0	17.0	14.2	9.6	10.5	16.4	X 22440-B4B	
	6 *	17.3	15.7	24	15.1	15.5	22.1	21.6	25.9	38.5	21.8	18.2	12.4	13.4	21.0	X 22440-B5B	
	7 *	23.6	21.5	32.9	20.7	21.2	30.3	29.6	35.5	52.8	29.9	24.9	17.0	18.4	28.8	X 22440-B6B	
	9 *	32	29	44.4	28	28.7	41.0	40.0	48.0	71.4	40.4	33.6	22.9	24.8	38.9	X 22440-B7B	
	10 *	37.2	33.8	51.7	32.6	33.4	47.7	46.6	55.8	83.0	47.0	39.1	26.7	28.9	45.3	X 22440-B8B	
	LJRE	11 *	45	40	62	40	40	57.8	56.5	67.7	100.7	57.0	47.4	32.3	35.1	54.9	
12 *		57	51	80	50	52	73.8	72.1	86.4	128.5	72.8	60.5	41.3	44.7	70.1	X 11873-B5B	
LERE	13 *	71	63	99	62	64	90.7	88.6	-	-	89.5	74.4	50.7	55.0	86.2	X 9117-B6B	
	14 *	81	72	112	71	73	103.7	101.3	-	-	102.3	85.1	58.0	62.9	98.5	X 9117-B7B	
	15 *	112	99	155	98	100	142.6	139.3	-	-	140.6	117.0	79.7	86.4	135.4	X 9117-B8B	
LIRE-	16 *	135	120	188	119	121	173.5	169.5	-	-	171.1	142.3	97.0	105.2	164.8	X 9117-B9B	
	17 *	174	154	241	152	156	222.4	217.2	-	-	219.3	182.4	124.3	134.8	211.2	X 9166-B10B	

Note 1: Nominal conditions: Evaporating Temperature +4°C (dew point), Condensing Temperature +38°C (bubble point), Subcooling 1 K

Note 2: For selection of other operating conditions, please use "Controls Navigator" selection program.

Note 3: *) Please indicate designation character for desired superheat.

Selection Table Power Assembly and Recommended Flanges

Valve Series	Orifice Type	Connection Standard Flange, Angle Style		Connection (Inlet x Outlet)		Power Element Type
		Type	Type	Metric	Imperial	
LCLE	X22440-B1B / B2B / B3B / B3.5B / B4B		C501-5	-	3/8" x 5/8" ODF	XB1019...2B
		C501-5mm		10x16 mm ODF		
	X22440-B5B / B6B		C501-7		1/2" x 5/8" ODF	
		C501-7mm		12x16 mm ODF		
			A576		5/8" x 7/8" ODF 7/8" x 1 1/8" ODF	
A576-mm		16x22 mm ODF 22x28 mm ODM	-			
LJRE	X11873-B4B / B5B	10331	10331	22x22 mm ODF	7/8" x 7/8" ODF 1 1/8" x 1 1/8" ODM	XC726...2B
LERE/ LIRE	X9117-B6B / B7B / B8B / B9B / B10B		9153	-	7/8" x 7/8" ODF 1 1/8" x 1 1/8" ODM	
		9153-mm		22x22 mm ODF 22x28 mm ODM		

Suction Gas Superheat Selection:

* Charge Code	Refrigerant												
	R134a	R404A / R507	R407C	R410A	R448A / R449A	R450A	R513A	R454A	R454C	R1234yf	R1234ze	R32	R455A
CL	-	22K	13K	30K	17K	-	-	19K	13K	-	-	31K	15K
GL	14K	-	25K	-	30K	10K	17K	32K	27K	16K	-	-	28K
UL	30K	-	-	-	-	26K	-	-	-	-	22K	-	-

Note: *) Please Indicate Designation Character for Desired Superheat.

Accessories and Spare Parts

Description	Type	Part No.
Service Tool for T, ZZ, L and 935 Series valves	X 99999	027 579
Gasket sets for T, ZZ, L and 935 Series valves	X 13455 -1	800 005
Gasket sets for T, ZZ, L and 935 Series valves Steel Screws for flange types: C500, C501, 9761, X6346, X6669, A576	Screw ST 32	803 573
Steel Screws for flange types: 9148, 9149, 9152, 9153, 10331, 10332	Screw ST 48	803 574
Bulb clamp for XB1019	XA 1728-4	803260
Bulb clamp for XC726	XA 1728-5	803261

Liquid Injection Valves Series 935

Exchangeable Power Assemblies and Orifices

Features

- Modular design for economical logistics and easy assembly and servicing
- Very good stability is attained because of the large forces generated by the large diaphragm diameter
- High-quality materials and processes for high reliability and long lifetime
- Combinations of different charges with various orifice springs cover a very large application range
- Max. allowable pressure PS:
 - 46 bar with XB power assembly
- Medium Temperature Range TS: -45...+65°C



Type Code Valve

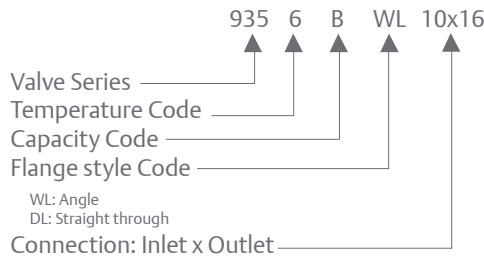

Type Code Power Assembly

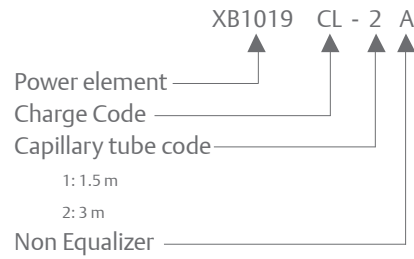

Nominal Capacities for Cages

Valve Series	Capacity code*	Nominal Capacity Q _n (kW)														Orifice Type	Power Element Type
		R134a	R32	R404A/R507	R407C	R410A	R448A/R449A	R450A	R454A	R454C	R455A	R513A	R452a	R1234yf	R1234ze		
935- *-	A	4.0	9.0	3.8	5.6	6.1	5.2	3.5	5.1	4.3	4.9	3.6	3.9	2.9	3.1	X10-**01	XB1019 - *** - 2A
	B	7.8	17.5	7.4	10.9	11.8	10.1	6.9	9.9	8.3	9.6	7.1	7.6	5.6	6.1	X10-**02	
	C	11.1	24.7	10.3	15.4	16.6	14.2	9.7	14.0	11.6	13.4	9.9	10.8	7.9	8.6	X10-**03	
	D	16.3	36.6	15.6	22.8	24.6	21.0	14.4	20.7	17.3	20	14.7	16.0	11.8	12.8	X10-**04	
	E	22.5	50.2	21.0	31.2	33.7	28.8	19.7	28.4	23.6	27.4	20.2	21.9	16.1	17.5	X10-**05	
	G	32.0	71.5	29.9	44.5	48.1	41.1	28.1	40.5	33.7	39.0	28.8	31.2	23.0	24.9	X10-**06	
	X	46.6	104.2	43.5	64.9	70.0	59.8	40.9	59.0	49.1	56.8	41.9	45.4	33.5	36.3	X10-**07	

*) Temperature Code	Temperature Range	**) Spring code	***) Charge code
3	-1 ... +17°C	B	UL
6	+14 ... +38°C	C	KL
105	+44 ... +70°C	C	YL
106	+66 ... +94°C	C	JL
100	+94 ... +121°C	C	LL

Note: Nominal conditions: Evaporating Temperature +4°C (dew point), Condensing Temperature +38°C (bubble point), Subcooling 1 K
For selection of other operating conditions, please use "Controls Navigator" selection program.

Selection Table Power Assembly and Recommended Flanges

Valve Series	Orifice Type	Connection Standard Flange, Angle Style		Connection (inlet x outlet)		Power Element Type
		Type	Type	Metric	Imperial	
935	X 10-*01/ *02/ *03	C501-5 mm		10 X 16 mm ODF		XB1019-***-2A
			C501-5		3/8" X 5/8 ODF	
	X 10-*04/ *05	C501-7 mm		12x16 mm ODF		
			C501-7		1/2"x5/8" ODF -	
	X 10-*06/ *07	A 576 mm		16x22 mm ODF 22x28 mm ODM		
			A 576		5/8"x7/8" ODF 7/8"x1-1/8" ODM	

Accessories and Spare Parts

Description	Type	Part No.
Service Tool for T, ZZ, L and 935 Series valves	X 99999	800005
Gasket sets for T, ZZ, L and 935 Series valves	X 13455-1	027579
Steel Screws for flange types: C500, C501, 9761, X6346, X6669, A576	Screw ST 32	803573
Bulb clamp for XB1019	XA 1728-4	803260

Overview Flange for Take Apart Valves

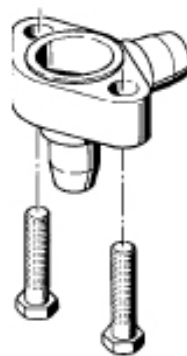

Angle Style Flange
(WL)

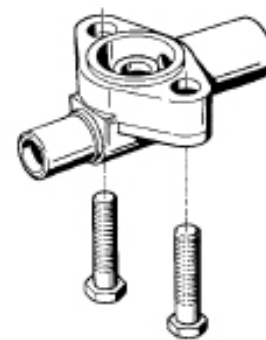

Straight Through Flange
(DL)

Flanges: T- / L-Series							
Valve Series	Orifice Type	Angle Style		Straight Through		Connection (Inlet x Outlet)	
		Type	Part No.	Type	Part No.	Metric	Imperial
TCLE / LCLE	X22440-B1B / B2B/ B3B / B3.5B / B4B	C501-5	803232	9761-3	803240	-	3/8"x5/8" ODF
		C501-5mm	803233	9761-3mm	803241	10x16 mm ODF	
	X22440-B5B / B6B	C501-7	803234	9761-4	803350		1/2"x5/8" ODF
		C501-7mm	803235	9761-4mm	803243	12x16 mm ODF	-
	X22440-B7B / B8B	-	-	6346-17	803330	16x22 mm ODF	5/8"x7/8" ODF
		A576	803238	-	-	-	5/8"x7/8" ODF
A576-mm		803239	-	-	16x22 mm ODF 22x28 mm ODM	7/8"x1-1/8" ODM	
TJRE / LJRE	X11873-B4B / B5B	10331	803338	10332	803324	22x22 mm ODF	7/8"x7/8" ODF 1-1/8"x1-1/8" ODM
TERE/ TIRE LERE/ LIRE	X9117-B6B / B7B / B8B / B9B / X9166-B10B	9153	803244	9152	803286	-	7/8"x7/8" ODF 1-1/8"x1-1/8" ODM
		9153-mm	803245	9152-mm	803287	22x22 mm ODF 28x28 mm ODM	
THRE	X9144-B11B / B13B	9149	803284	9148	803283	22x22 mm ODF	7/8"x7/8" ODF 1-1/8"x1-1/8" ODM

Flanges: 935- / ZZ-Series							
Valve Series	Orifice Type	Angle Style		Straight Through		Connection (Inlet x Outlet)	
		Type	Part No.	Type	Part No.	Metric	Imperial
935 / ZZ	X10-*01 / *02 / *03	C501-5	803232	9761-3	803240	-	3/8"x5/8" ODF
		C501-5mm	803233	9761-3mm	803241	10x16 mm ODF	
	X10-*04 / *05	C501-7	803234	9761-4	803350		1/2"x5/8" ODF
		C501-7mm	803235	9761-4mm	803243	12x16 mm ODF	-
	X10-*06 / *07	-	-	6346-17	803330	16x22 mm ODF	5/8"x7/8" ODF
		A576	803238	-	-	-	5/8"x7/8" ODF
A576-mm		803239	-	-	16x22 mm ODF 22x28 mm ODM	7/8"x1-1/8" ODM	