

CONVENTIONAL OIL SEPARATORS

The function of a Conventional Oil Separator is to remove oil from the discharge gas and return it to the compressor, either directly or indirectly. This helps maintain the compressor crankcase oil level and raises the efficiency of the system by preventing excessive oil circulation.

Applications

Conventional oil separators can be used in a wide variety of applications.

Common applications include multi-compressor racks and remote condensing units.

Conventional oil separators are intended for Low Pressure Oil Management Systems, using HCFC, HFC, R290 & A2L gases and their associated oils, compatible with the vessel materials.

These separators are designed for use with scroll and reciprocating type compressors. They are not recommended for screw or rotary vane compressors.

How it works

Oil-laden refrigerant gas from the compressor enters the separator and passes through an inlet screen. On entering the separator, the velocity of the gas is reduced. This reduction in velocity causes a change in momentum. The fine oil particles collide with one another to form heavier particles, which adhere to the inlet screen and inside wall of the separator.

The gas then passes through an outlet screen where final separation takes place. Refrigerant gas, with the majority of oil removed, then exits the separator.

The separated oil falls to the bottom of the separator where a float operated needle valve returns the oil to the crankcase or oil reservoir in the same way as the helical oil separator.

With proper selection, oil separation efficiency is typically 80%.

Main Features

- Low pressure drop
- Cleanable/replaceable oil float assemblies for S-19* models

Technical Specification

Allowable operating pressure = 0 to 31 barg

Allowable operating temperature = -10°C to +130°C

Materials of Construction

The main components; shell, end caps and connections are made from carbon steel. The oil float is made from stainless steel. The needle valve seat is made from steel.



CONVENTIONAL OIL SEPARATORS

Part No	Conn Size (inch)	Dimensions (mm)					Mounting details	Drawing reference	Weight (kg)	Pre-charge qty (l)	CE Cat
		Ø A	B	C	D	E					
S-5580	1/4 ODS	102	210	48	N/A	N/A	M10	fig.1	2.5	0.4	Cat I
S-5581	3/8 ODS	102	208	48	N/A	N/A	M10	fig.1	2.4	0.4	Cat I
S-5582	1/2 ODS	102	260	48	N/A	N/A	M10	fig.1	2.9	0.4	Cat I
S-5585	5/8 ODS	102	362	48	N/A	N/A	M10	fig.1	3.6	0.4	Cat II
S-5587	7/8 ODS	102	451	48	N/A	N/A	M10	fig.1	4.2	0.4	Cat II
S-5588	1 1/8 ODS	102	532	48	N/A	N/A	M10	fig.1	4.8	0.4	Cat II
S-5590	1 3/8 ODS	102	539	48	N/A	N/A	M10	fig.1	4.9	0.4	Cat II
S-5690	1 3/8 ODS	152	397	76	N/A	N/A	3/8	fig.1	7.9	0.9	Cat II
S-5692	1 5/8 ODS	152	473	76	N/A	N/A	3/8	fig.1	8.9	0.9	Cat III
S-5694	2 1/8 ODS	152	486	76	N/A	N/A	3/8	fig.1	9.3	0.9	Cat III
S-1901/P	1 5/8 ODS	203	534	89	99	162	3 x Ø 14mm slots	fig.2	16	0.7	Cat III
S-1902/P	2 1/8 ODS	203	534	89	99	162	3 x Ø 14mm slots	fig.2	16	0.7	Cat III
S-1903/P	2 5/8 ODS	256	545	118	76	213	3 x Ø 14mm slots	fig.3	20	0.7	Cat III
S-1904/P	3 1/8 ODS	305	654	141	81	266	3 x Ø 14mm slots	fig.3	36	0.7	Cat III

Note: S-1903P and S-1904P include 2 x 3/8" NPT fittings for PRVs.

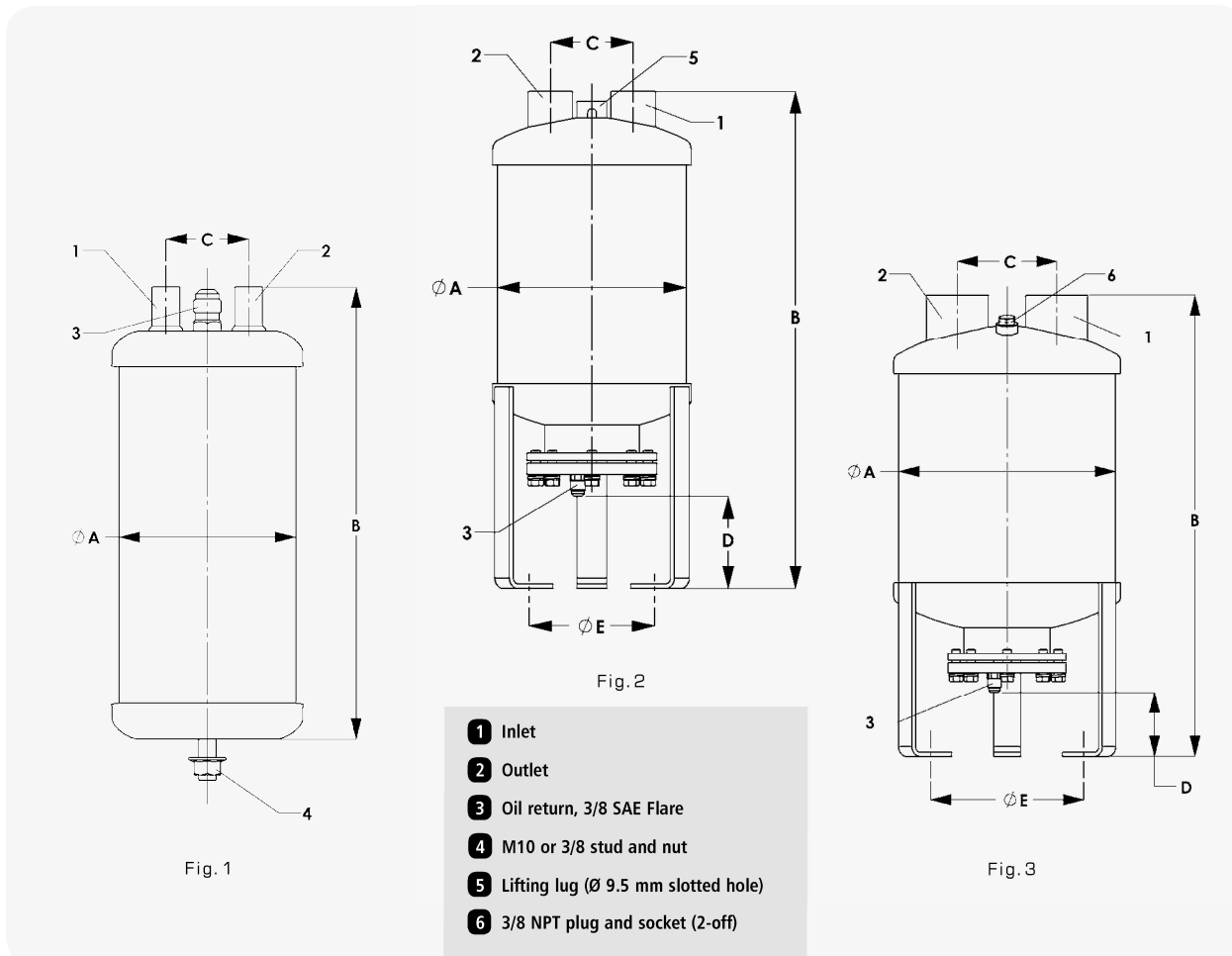

Performance data

This table provides a summary of the kW capacity of each separator for fixed evaporating and condensing temperatures.

This table can be used as a quick reference guide. However, the Selection Guidelines are recommended for conventional oil separator sizing.

Part No	Capacity in kW of refrigeration at nominal evaporator temperature						Maximum discharge volume (m ³ /hr)
	R404A/507		R134a		R407F		
	-40°C	5°C	-40°C	5°C	-40°C	5°C	
S-5580	2.9	3.7	3.1	3.5	3.4	4	1.3
S-5581	3.8	4.9	4.2	4.7	4.5	5.2	1.7
S-5582	5.7	7.4	6.3	7.1	6.8	8	2.6
S-5585	15.2	19.7	16.8	19	17.8	20.8	6.8
S-5587	22.8	29.5	25.1	28.4	26.7	31.3	10.2
S-5588	30.4	39.3	33.5	37.8	35.6	41.7	13.6
S-5590	38	49.2	42	47.3	44.5	52.1	17
S-5690	41.8	54.1	46.1	52	49	57.3	18.7
S-5692	53.2	68.8	58.6	66.1	62.4	72.9	23.8
S-5694	85.6	110	94.3	106	100	117	38.3
S-1901/P	68.4	88.5	75.4	84	80.2	93.7	30.6
S-1902/P	102	132	113	127	120	141	45.9
S-1903/P	186	240	205	231	218	255	83.3
S-1904/P	258	334	284	321	301	352	115

Notes: All data is for a 38°C condensing temperature, 18°C suction temperature and on connection size being the same as the compressor discharge valve.

Selection Guidelines

The most important parameter for selection is the discharge volumetric flow rate, expressed in m³/hr. This is the calculated volumetric flow rate at entry to the oil separator. It is not to be confused with the compressor displacement or swept volume.

A quick method is to use the selection graphs. For HCFC and HFC refrigerants, the same graphs apply for both conventional and helical oil separators. Conventional separators are not suitable for use with ammonia hence the R717 graph should not be used.

As with the helical separators, where a higher degree of accuracy is required to calculate the m³/hr, the flow rate calculation method is recommended. The flow rate calculation method is also recommended for special applications.

Conventional Separator Selection using the Graphs

To use the selection graphs, the refrigerant type, maximum refrigeration capacity, minimum refrigeration capacity, evaporating temperature and the condensing temperature is required.

Example:

Refrigerant R404A

Maximum refrigeration capacity = 100 kW

Minimum refrigeration capacity = 50 kW

Evaporating temperature = -10°C

Condensing temperature = +40°C

From the R404A graph, follow the -10°C evaporator temperature line to the intersection of the 40°C condensing temperature line.

Extend a line horizontally from this point to the m³/hr/kW factor.

Multiply this factor by the maximum and minimum refrigeration capacities to compute the maximum and minimum discharge volume flow rates.

From the R404A graph, the [m³/hr/kW factor] = 0.355

Therefore:

Maximum discharge volume flow rates = (0.355 x 100) = 35.5 m³/hr

Minimum discharge volume flow rates = (0.355 x 50) = 17.75 m³/hr

The maximum and minimum m³/hr figures should be compared with the rated capacity of the conventional separator. Refer to the Performance Data Table for the rated capacities.

The general recommendation is that the calculated maximum flow should not exceed the rated capacity of the separator. Also, the minimum flow should not be below 33% of the rated capacity.

Using these m³/hr figures, the recommended conventional separator selection is model S-5694 with a rated capacity of 38.3 m³/hr.

Additional notes on selection

1. The 33% minimum recommendation rule is to optimise efficiency. Below this load factor, the efficiency of the separator will decrease. On systems with extreme unloading conditions, one separator per compressor should be used rather than one separator for a common discharge line.
2. Understanding the system refrigeration capacity and the percentage of full and low load run times can also be helpful in selecting the separator.
3. In cases where the maximum discharge has been exceeded by only a minimal amount and the system has unloading characteristics, select the smaller separator. It is not recommended to oversize.

Installation – Main issues

Refer to helical oil separators section.